

brother®

ELECTRONIC PROGRAMMABLE PATTERN TACKER

bro rom
INDUSTRIAL MACHINES

Str. Fabrica de Glucoza 2-4, sector 2, Bucuresti, Romania
Nr. Reg. Com.: J 40/5796/1997, C.U.I: R9645361
Tel./Fax: +01 2323.844, +01 232.969, +01 2323.87
Www.brother.ro www.brorom.ro email:office@brother.ro

BAS-326

INSTRUCTION MANUAL

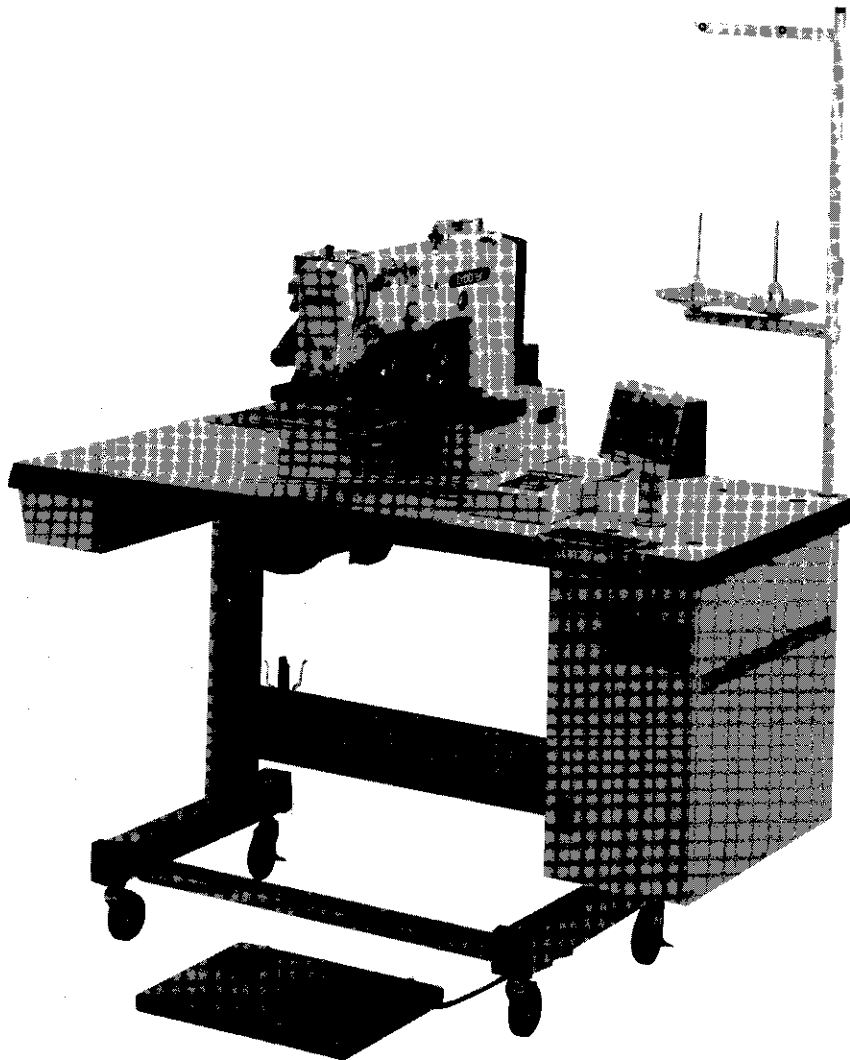

CONTENTS

MAIN PART NAMES	1
SPECIFICATIONS	1
INSTALLATION	2
① Positioning	2
② Installation of spool stand	2
③ Cord connections	2
④ Installation of eye guard	2
⑤ Tilting the sewing machine head	2
⑥ V-belt tension	3
LUBRICATION AND OIL DRAINING	3
① Adding oil	3
② Oil draining	4
CORRECT OPERATION	4
① Needle installation	4
② Upper thread threading	4
③ Bobbin thread winding	5
④ Bobbin case installation and threading	6
⑤ Thread tension	7
OPERATING PROCEDURE	8
① Operation panel part names and functions	8
② Using the floppy disk	9
③ Using the bobbin thread counter	9
④ Using the program R/W switch	10
⑤ Using the STEP BACK switch	11
⑥ Adjusting the sewing SPEED control	11
⑦ Using the TEST switch	12
⑧ Using the emergency stop switch	12
⑨ Shifting a stitch pattern	13
SEWING	14
STANDARD ADJUSTMENTS	15
① Needle bar height adjustment	15
② Needle bar lift stroke adjustment	15
③ Needle to shuttle hook point gap adjustment	15
④ Shuttle driver needle contact adjustment	16
⑤ Shuttle hook thread guide adjustment	16
⑥ Movable knife adjustment	17
⑦ Presser foot adjustment	18
⑧ Changing the presser foot lift	18
⑨ Thread wiper adjustment	19
⑩ Needle and feed timing adjustment	19
⑪ Origin adjustment	20
⑫ 2-step work clamp operation adjustment	21
OPERATION FLOW CHART	23
ERROR NO. LIST	24
DIP SWITCH SETTINGS	24

MAIN PART NAMES

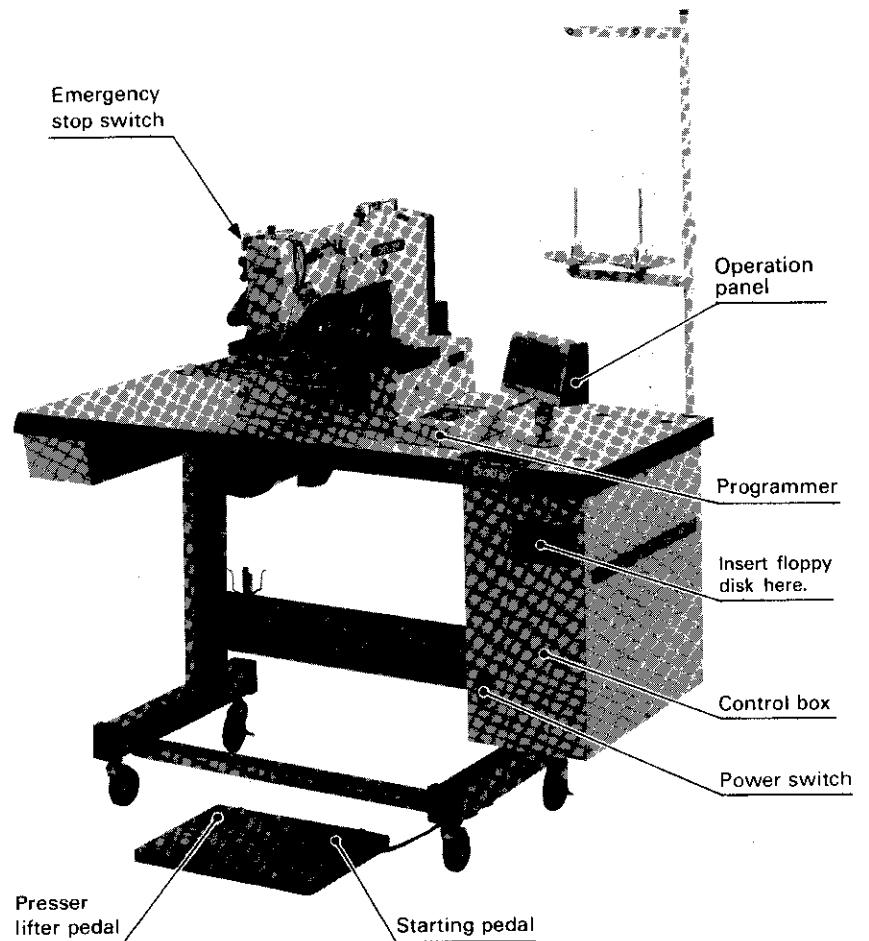
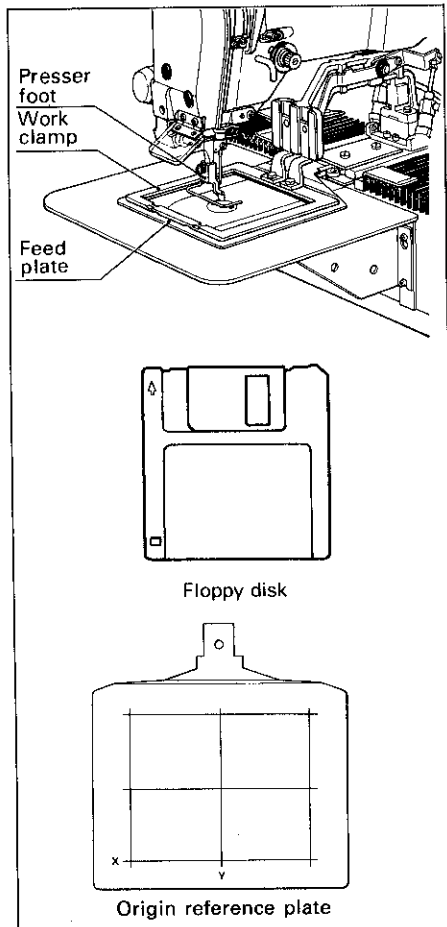

SPECIFICATIONS

Stitch type	Single needle, lock stitch			
Sewing machine	Lock stitch, pattern tacking sewing machine (with large shuttle hook)			
Stitch length and max. sewing speed	0.2 ~ 3.0 mm	3.2 ~ 4.4 mm	4.6 ~ 6.2 mm	6.4 ~ 8.0 mm
	1,000 ~ 2,000 spm	750 ~ 1,500 spm	600 ~ 1,000 spm	600 ~ 800 spm
Feed format	Intermittent feed, pulse motor drive			
Max. pattern size	X-axis, 150 mm standard, 180 mm Large specification (wide); Y-axis, 100 mm (deep)			
Number of stitches	Max. 2,000 (one pattern)			
Work clamp lift stroke	Max. 20 mm			
2-step presser foot	Right/left selectable			
Intermittent feed	Max. 7 mm			
Test function	Operation test function provided for use with low speed drive			
Safety devices	Automatic stop function for activation in the event of misoperation realized with intermediate stop function and safety circuits.			
Machine dimensions	1200W x 590D x 1140H mm (Sitting) ~ 1350H mm (Standing)			
Power table	T-shaped for use sitting or standing			
Standard accessories	Floppy disks			
Power source	1-phase 110V, 200V, 220V, 240V 3-phase 220V, 380V, 415V			
Motor	Three phase induction motor 400W			

INSTALLATION

1 Positioning

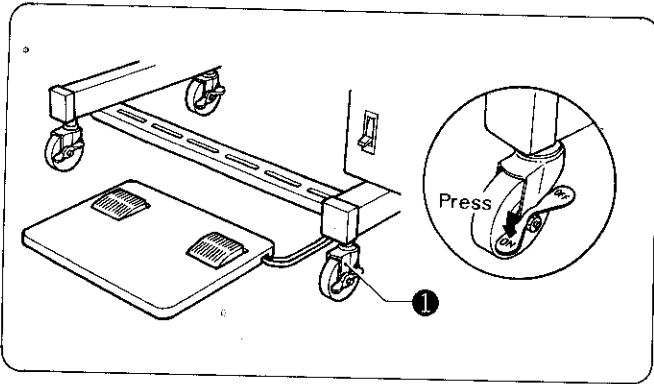

Determine the position for the sewing machine, and then lock the casters ① so that the sewing machine will not move.

2 Installation of spool stand

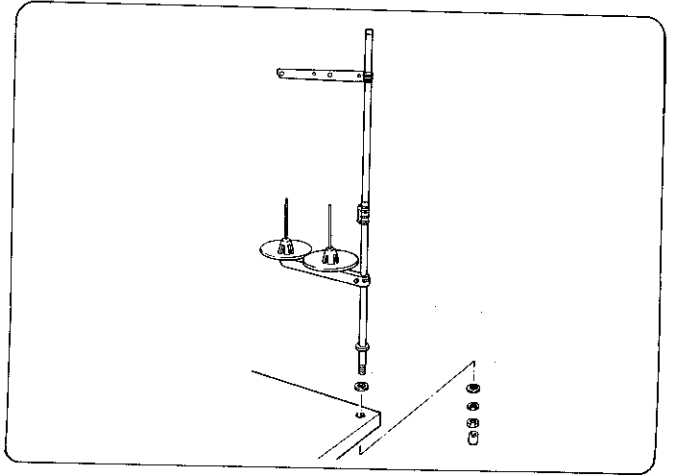

Install the spool stand to the table.

3 Cord connections

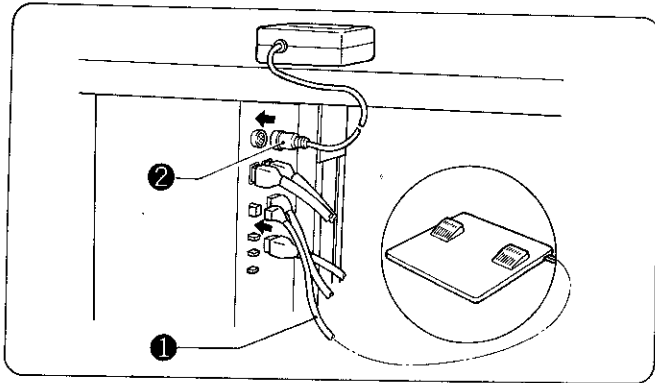

Connect the cord for the pedal ①, and the programmer ② to their respective terminals

4 Installation of eye guard

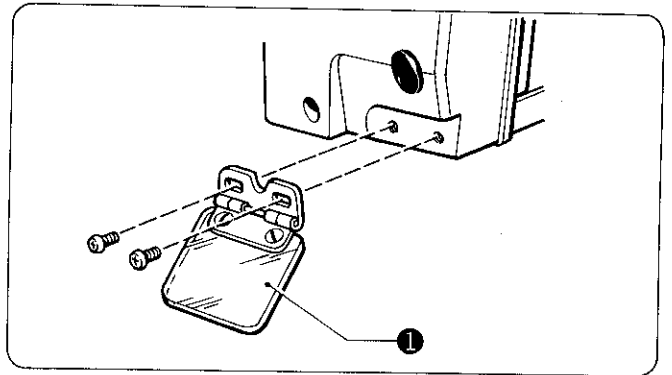

Install the eye guard ① on the machine head.

5 Tilting the sewing machine head

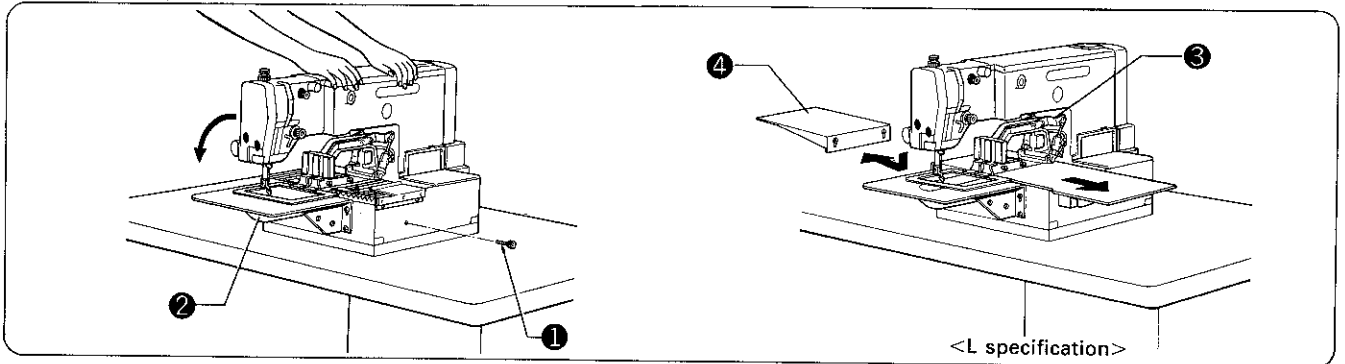

<L specification>

- (1) Remove head lock bolt ①.
 - (2) Stand at the left side of the table, and gently tilt the machine towards you. When returning the machine to the original position, be careful of the shuttle hook cover ② and the cord.
- ※ On L specification, first move the presser arm ③ all the way right and remove the feed cover support L ④ before tilting the machine.

6 V-belt tension

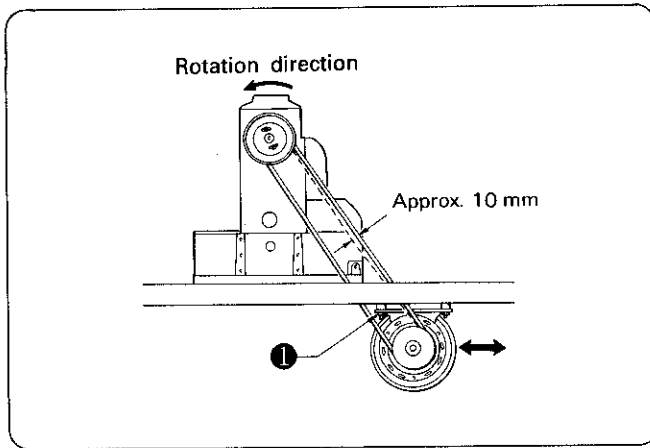

There should be approximately 10 mm of give when the V-belt is pressed at the center. To adjust, loosen the four nuts ❶, and shift the motor right or left.

LUBRICATION AND OIL DRAINING

1 Adding oil

★ Be sure to use Brother-specified machine oil (Nisseki Sewing Lub. 10).

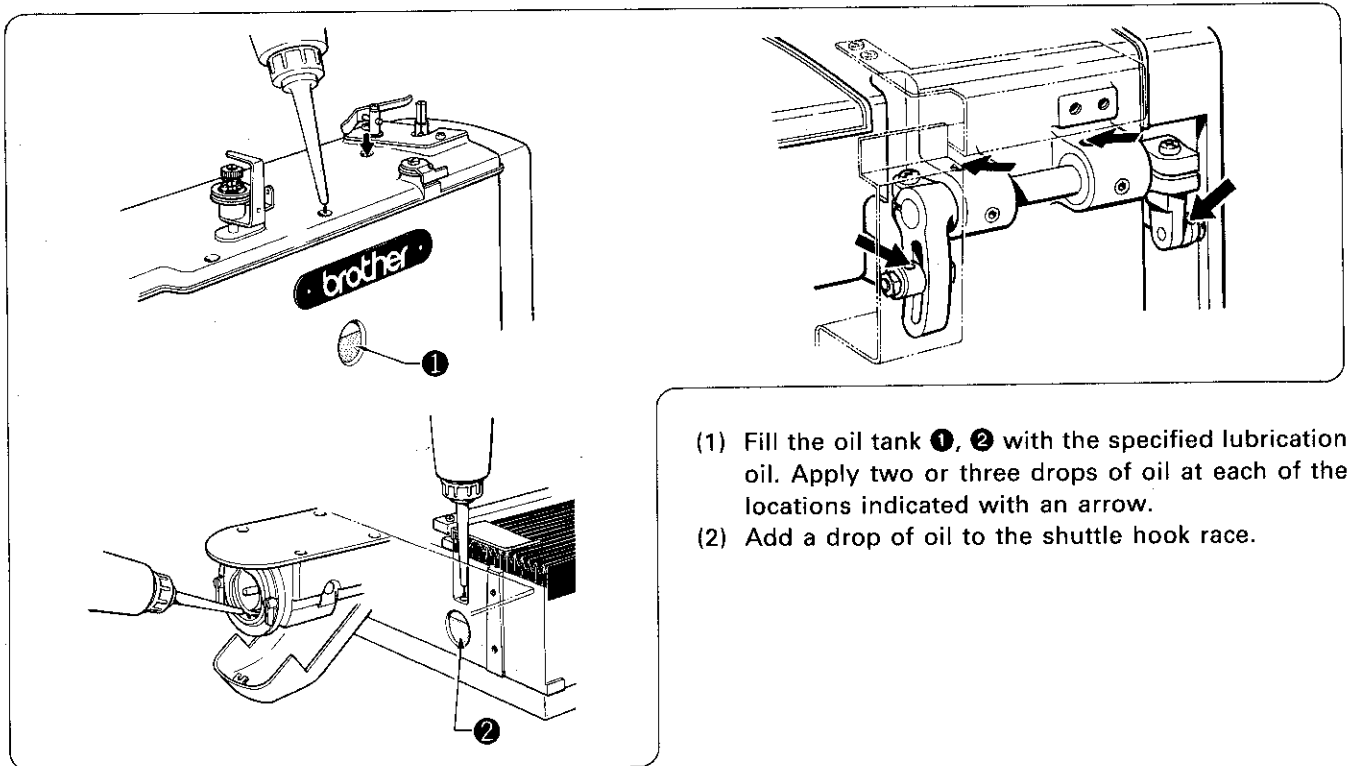

- (1) Fill the oil tank ❶, ❷ with the specified lubrication oil. Apply two or three drops of oil at each of the locations indicated with an arrow.
- (2) Add a drop of oil to the shuttle hook race.

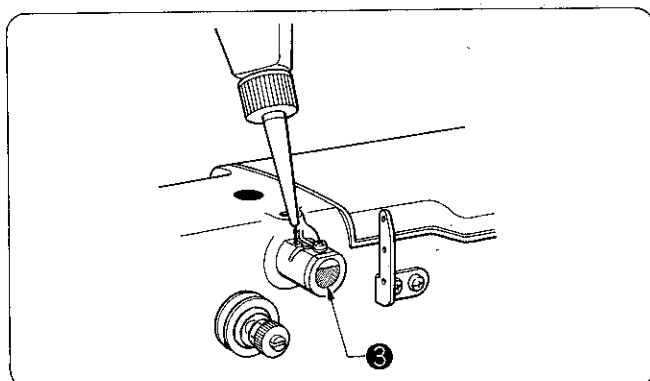

- (3) Fill the cooling tank ❸ with silicon oil.

2 Oil draining

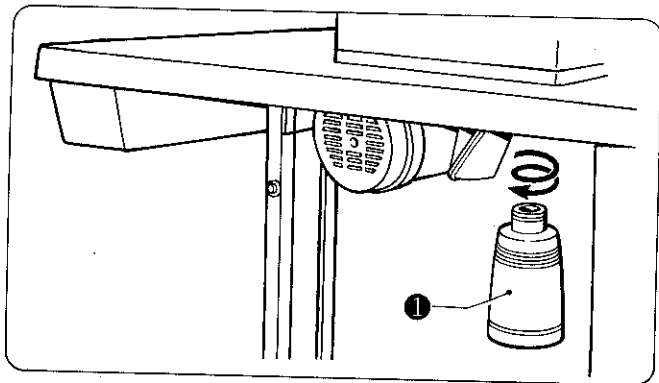

★ Remove and empty the oil drain ① wherever it is full.

CORRECT OPERATION

1 Needle installation

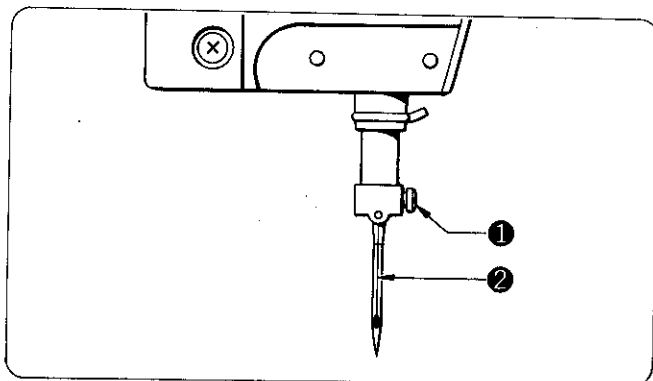

★ Loosen set screw ①. Fully insert the needle ② with the groove facing the front, and then retighten set screw ①.

2 Upper thread threading

★ Thread the upper thread as shown in the diagrams below.

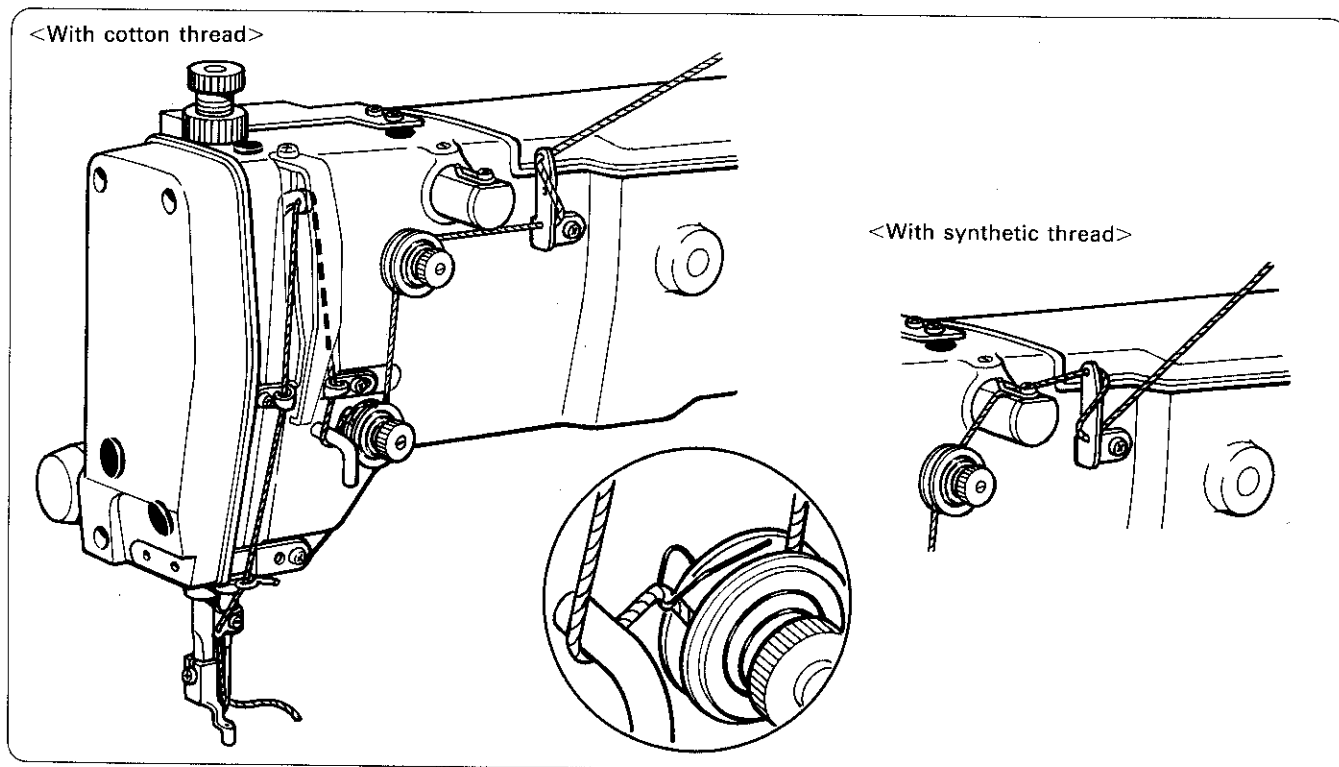

3 Bobbin thread winding

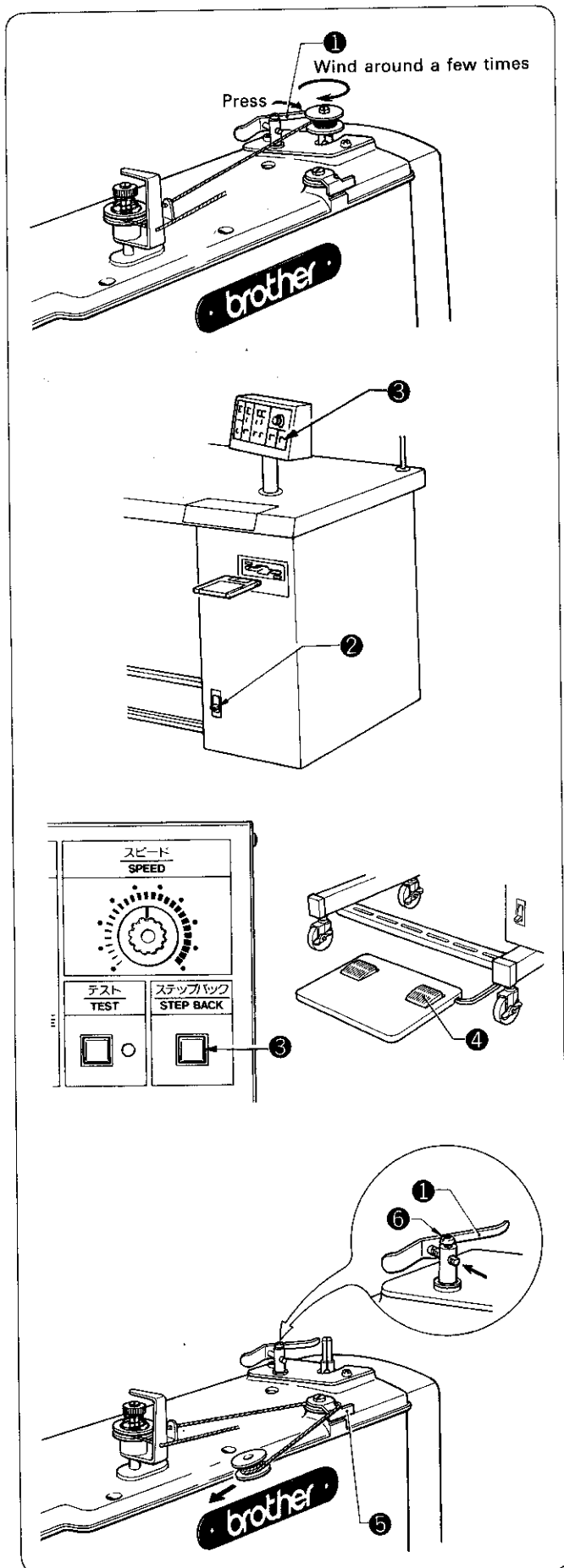

- (1) Slide the bobbin ① all the way onto the spindle.
- (2) Thread the thread as shown in the figures, and wind the thread around the bobbin ① several times in the direction of the arrow.
- (3) Turn the power switch ② on. (The power indicator on the operation panel will light.)
- (4) Press and hold the step back switch ③ on the operation panel, and depress the starting pedal ④ to start the sewing machine. Keep the starting pedal depressed until the bobbin is fully wound. (Release the step back switch ③ when the sewing machine starts.)
- (5) The bobbin holder ① will automatically return when the bobbin is filled to capacity (approximately 80 ~ 90% of the bobbin diameter.)
- (6) Release the starting pedal ④.
- (7) Remove the bobbin, and pull the bobbin in the direction of the arrow to cut the thread on the thread cutter ⑤.
- (8) To wind more thread onto the bobbin, loosen set screw ⑥ to move the bobbin holder ① out.

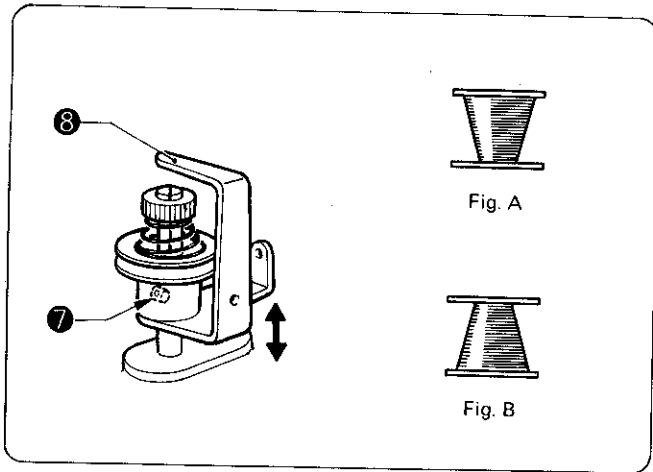

- If the thread winds onto the bobbin tapered as shown in the figures, loosen set screw 7 and raise or lower thread guide 8 so that the thread winds evenly.
- ★ If the thread tapers as shown in Fig. A, raise, and if the thread tapers as shown in Fig. B, lower thread guide 8.

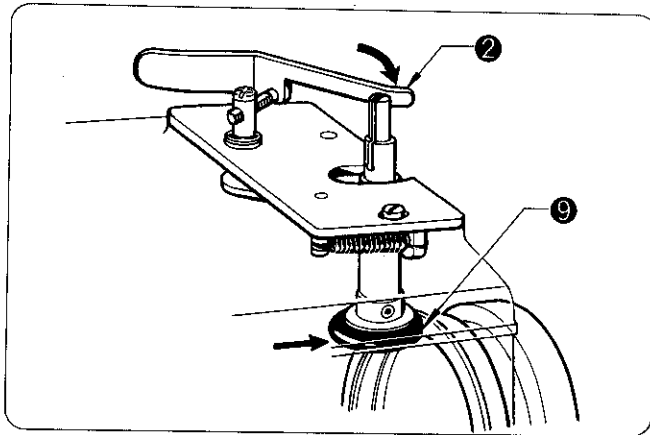

<Bobbin winder mounting>

Press the bobbin winder stop latch 2 to the winding position, and press the thread winder O-ring 9 1 mm toward the machine pulley.

4 Bobbin case installation and threading

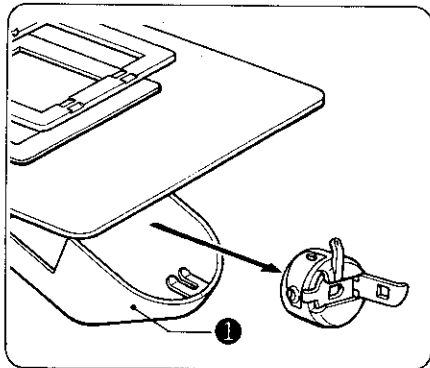

- (1) Pull the shuttle race cover 1 forward and then open the cover.
- (2) Lift the bobbin case latch and remove the bobbin case.

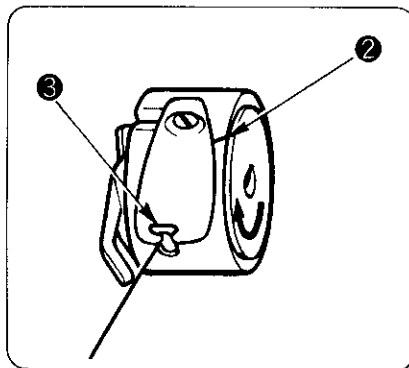

- (3) Insert the bobbin into the bobbin case, pass the thread through the cut line 2, and pull it out through the thread hole 3. Make sure the bobbin turns in the direction of the arrow when the thread is pulled.

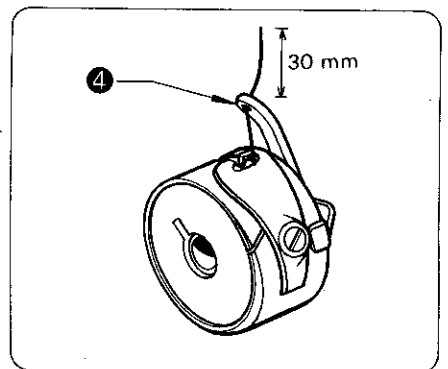

- (4) Pass the end of the thread through the thread hole 4 in the horn, and pull approximately 30 mm of thread out.

5 Thread tension

1. Bobbin thread tension

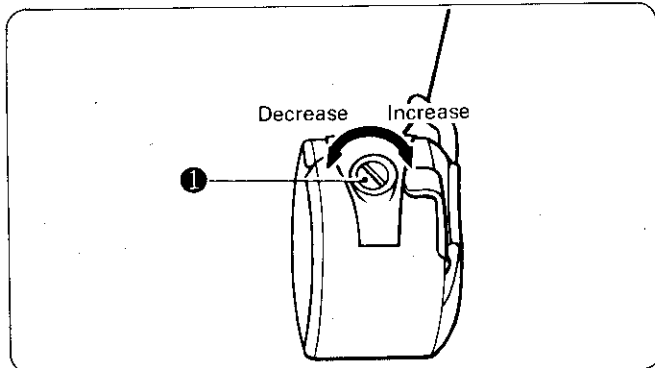

★ The bobbin thread tension should be adjusted so that the bobbin will not descend of its own weight when the suspended by the bobbin thread. Turn adjustment screw ① to adjust.

2. Upper thread tension

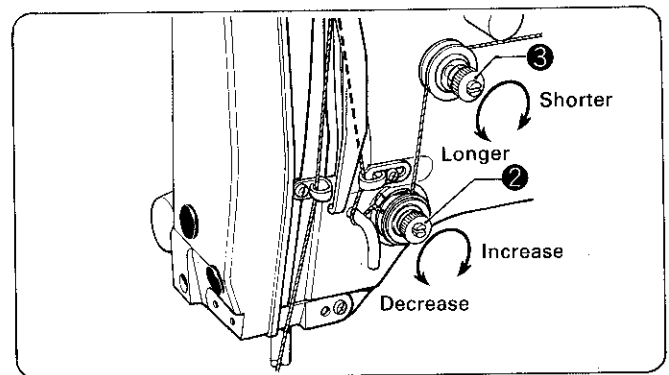

Turn the thread tension control nut ② to adjust the upper thread tension to the material being sewn. Adjust thread tension control nut ③ so that the thread remainder is between 35 to 40 mm.

3. Thread take-up spring height

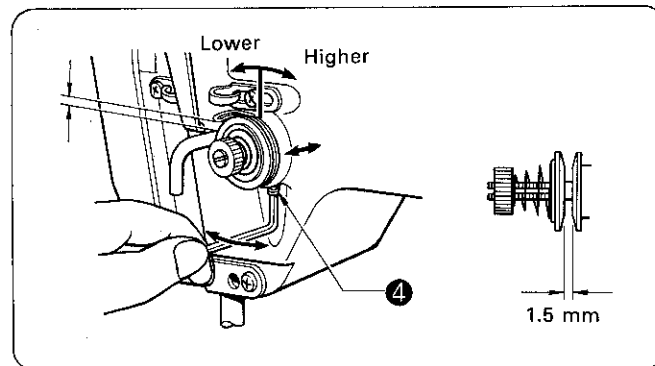

To adjust the height of the thread take-up spring, loosen set screw ④ and turn the entire adjustment unit.

Also, slide the adjustment unit in or out so that the tension disc opens approximately 1.5 mm after the final stitch.

4. Thread take-up spring tension

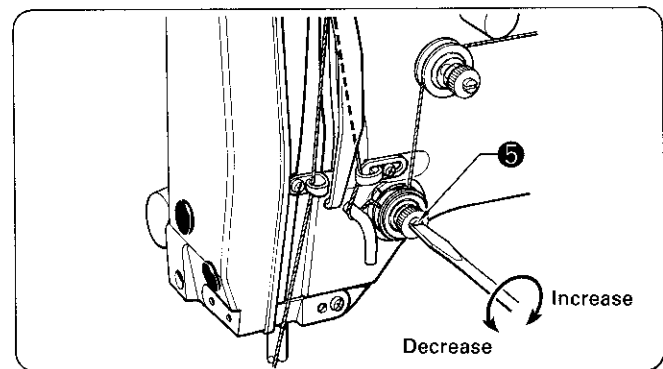

Adjust the thread take-up spring tension by turning the tension stud ⑤ with a screwdriver.

5. Upper thread tension release timing

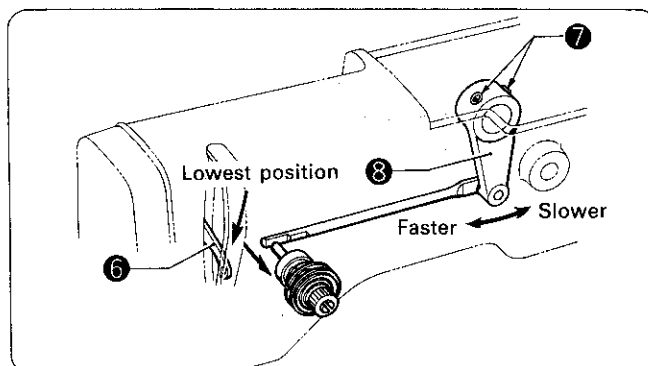

Loosen set screw ⑦ and adjust the position of the upper thread tension release lever ⑧ so that the tension on the upper thread is released when the thread take-up lever ⑥ is completely lowered at the end of a stitch.

OPERATING PROCEDURE

1 Operation panel part names and functions

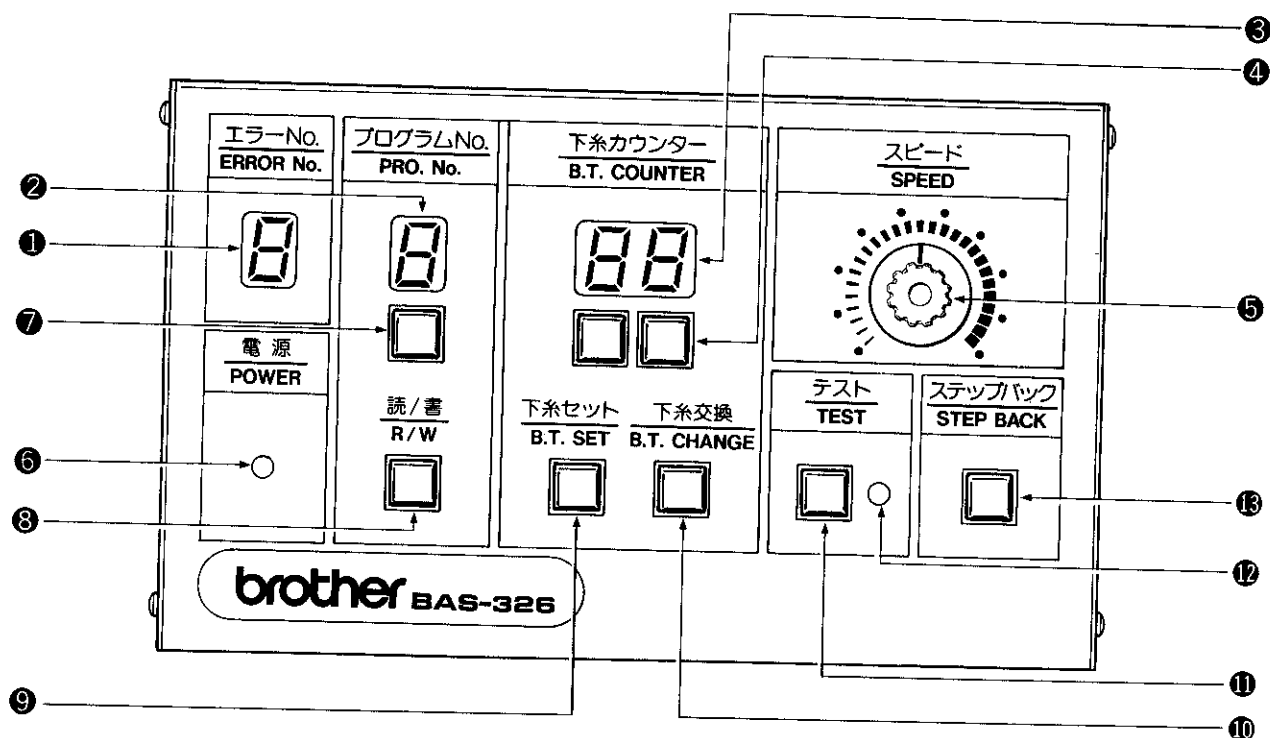

- ① ERROR No. display Used to display error numbers 1 ~ 9 and A.
- ② PROGRAM No. display Displays the program number 0 ~ 9.
- ③ Bobbin Thread COUNTER Shows the number (00 ~ 99) of pieces sewn.
(Decrementing type; the number decrements one each time a single stitch pattern is completed, indicating the remaining bobbin thread.)
- ④ Bobbin Thread COUNTER switches ... Used to set the number of work pieces in the bobbin thread counter.
- ⑤ SPEED control Used to change the sewing speed.
(The sewing speed can be adjusted in ten steps according to the stitch length.)
- ⑥ POWER indicator Lights when the power is turned on.
- ⑦ Program select switch Used to select the program number when reading a program from or writing a program to disk.
- ⑧ Program Read/Write switch Used to read a program from floppy disk, or to write a newly programmed stitch pattern to floppy disk.
Up to ten patterns (0 ~ 9) can be stored on each disk.
- ⑨ Bobbin Thread SET switch Used to store the number of work pieces displayed in the bobbin thread counter to floppy disk.
- ⑩ Bobbin Thread CHANGE switch ... Used to continue sewing after replacing the bobbin thread.
(An alarm will sound when the counter reads <00>. Sewing is not possible when the counter reads <00>.)
- ⑪ TEST switch Used to confirm a programmed stitch pattern.
- ⑫ TEST indicator Lights when the TEST switch is pressed.
- ⑬ STEP BACK switch Used when winding a fresh bobbin, or when correcting a stitch pattern due to a broken needle thread.

2 Using the floppy disk

- ★ Programs for up to ten programs each containing up to a maximum 2,000 stitches can be stored on each floppy disk.

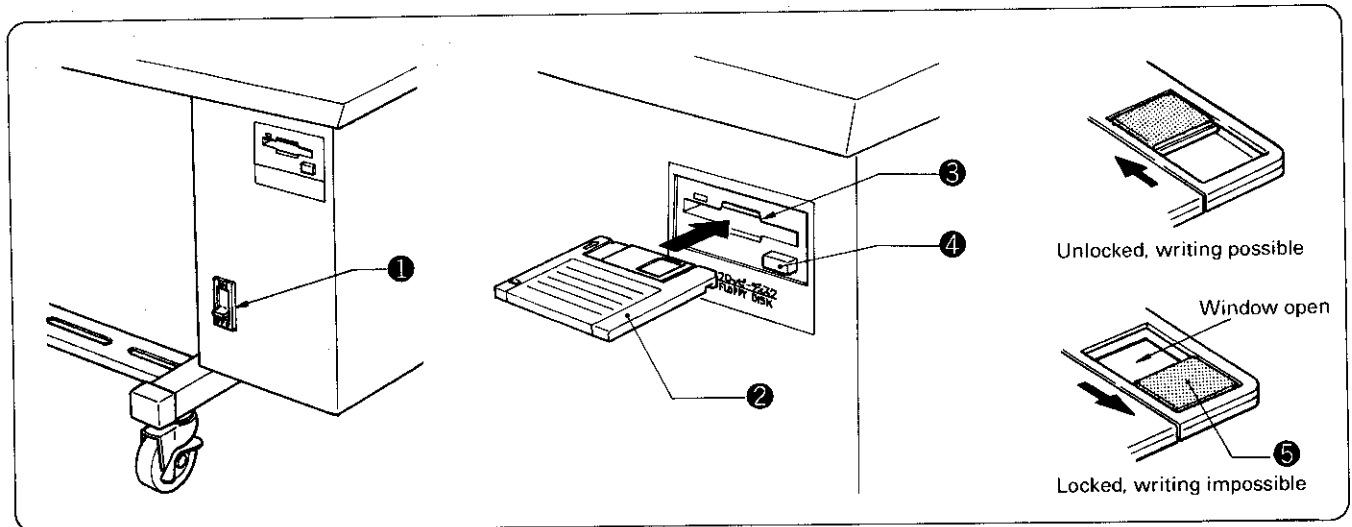

- (1) Turn the power switch ① on.
 - (2) Hold the disk ② with the label up and the metal shutter to the front, and insert the disk into the drive ③. It will click into place.
 - (3) To eject the disk, press the eject button ④.
- ※ Slide the write protector ⑤ on the back of the disk up (the window opens) to lock the disk and prevent accidental erasure of the disk contents.
 - ※ Inserting the disk into the drive upside down or backwards may damage the drive and will prevent reading or writing of data.
 - ※ Be sure to store your disks away from any magnets or magnetic sources, including radios, televisions, telephones, and other devices. Magnetism can erase or damage disk contents. Also, be careful to prevent exposure of the disk to oil or dust.

3 Using the bobbin thread counter

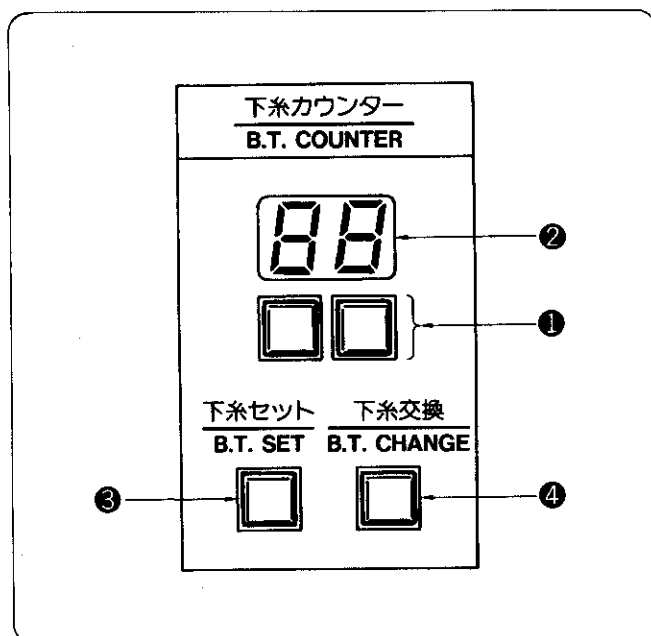

- ★ Set the bobbin thread counter to display the number of pieces of the selected pattern which can be sewn with the amount of thread on the bobbin to avoid running out of bobbin thread in the middle of a pattern.
- (1) Press the bobbin thread counter switches ① to display the number of work pieces in the bobbin thread counter ②.
- ※ The bobbin thread counter can be set to any number from <01> to <99>. If the counter is set to <00>, sewing continues irrespective of the amount of bobbin thread remaining.
- (2) Insert the floppy disk and press the bobbin thread set switch ③. An alarm will beep twice. This will record the number of work pieces shown in the bobbin thread counter ② to the disk.
 - (3) The number shown in the counter ② will decrement one each time the stitch pattern is completed. When the number of patterns shown in the counter is sewn, the counter ② will read <00>, and an alarm will sound. (The sewing machine will not start even if the start switch is pressed.)
 - (4) Press the bobbin thread change switch ④ and replace the bobbin. The alarm will stop, and the number of work pieces set in step (2) will be displayed again in the bobbin thread counter ②.

4 Using the program R/W (Read/Write) switch

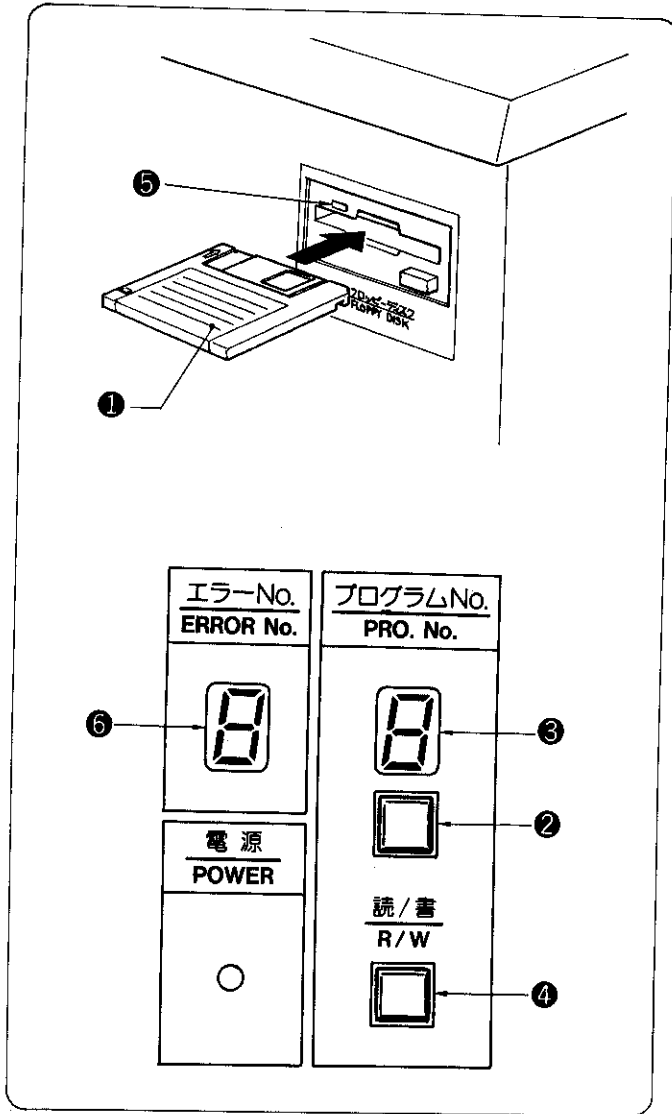

* Programmed stitch patterns stored on floppy disk can be read into memory, and newly programmed patterns can be written to disk for permanent storage and later recall.

(1) Insert the floppy disk ① containing or which is to contain the programmed stitch pattern.

(2 — 1) To READ a pattern to memory

Press the PRO. No. ② on the operation panel to display the number of the programmed stitch pattern in the program number display ③. After selecting the desired program number, press the R/W switch ④. The drive indicator ⑤ will light, and the program will be read into memory. When the alarm sounds and the indicator ⑤ goes out, reading is completed.

(2 — 2) To WRITE a pattern to disk

Press the PRO. No. ② on the operation panel to display the number of the desired programmed stitch pattern. After programming the pattern with the stitch programmer, press the R/W switch ④. The drive indicator ⑤ will light, and the program will be written to disk. When the alarm sounds and the indicator ⑤ goes out, writing is completed.

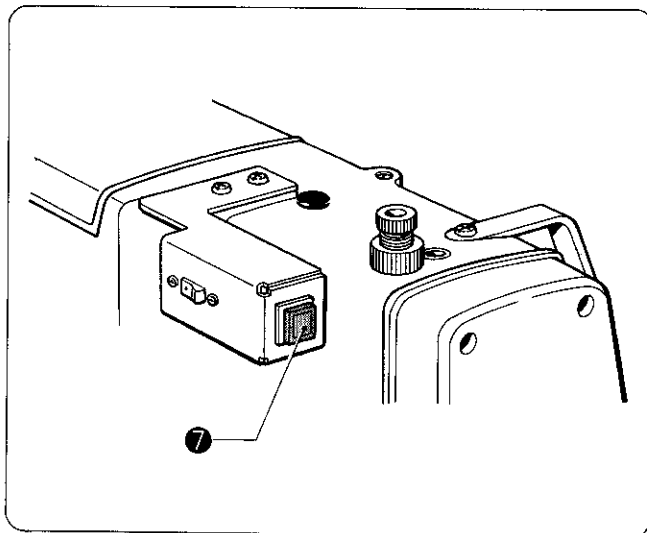

* If an error message is displayed

If an error message code (1 ~ 9, A) is displayed in the error No. display ⑥, an alarm will sound. Press the emergency stop switch ⑦ on the front of the machine to stop sewing machine operation, and then refer to and follow the error code list on page 24.

5 Using the STEP BACK switch

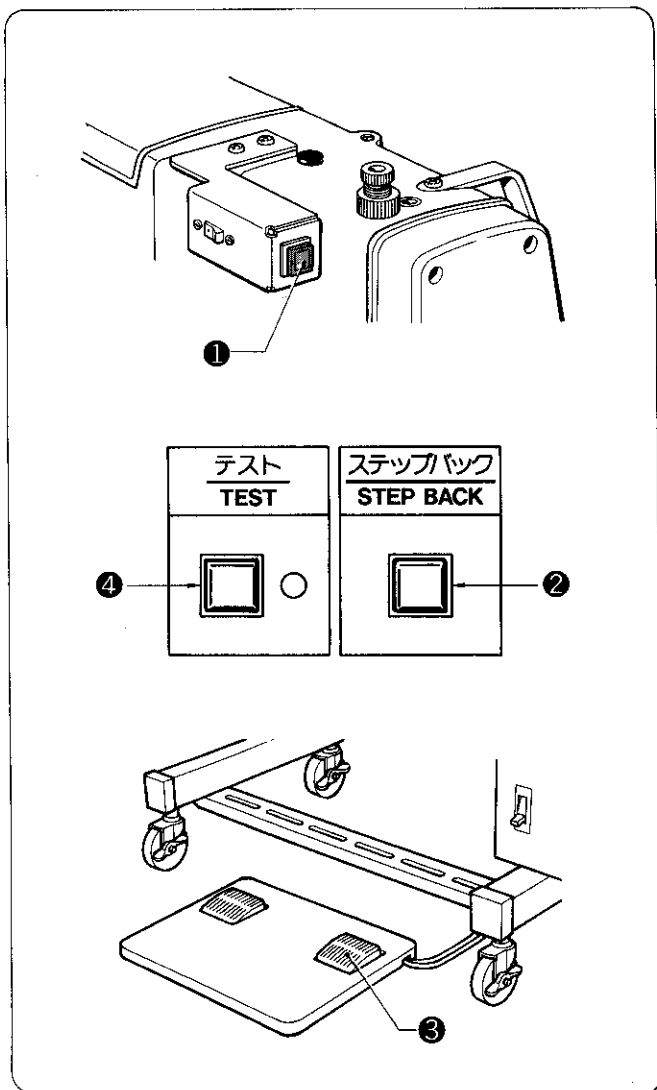

★ This switch is used to move the machine one stitch at a time in the reverse sewing direction to enable resewing in the event the thread breaks or the bobbin thread runs out in mid-pattern. Use this switch to return to the point where the thread broke or run out. This is especially useful with large patterns.

- (1) Press the emergency stop switch ① while the machine is running. All operations will stop and the emergency stop lamp will illuminate.
 - (2) Press the emergency stop switch ① once again. The emergency stop lamp will go out.
 - (3) Press the step back switch ②. The work clamp will reverse one stitch at a time as long as the step back switch is depressed.
 - (4) When the work clamp has returned to the desired position, release the step back switch. If the work clamp is stopped too soon, simply press the step back switch again to resume reverse work clamp movement.
 - (5) The machine will start sewing when the starting pedal ③ is pressed.
- ※ Turn the test switch ④ on and press the starting pedal ③ to move the work clamp one stitch at a time forward. The work clamp will advance in 100 stitch units if the step back switch is pressed at this time.

6 Adjusting the sewing SPEED control

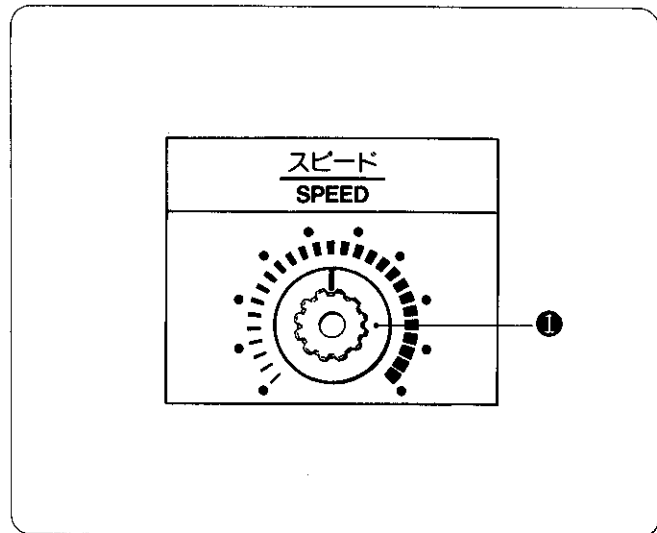

- (1) The actual sewing speed can be adjusted in ten steps through the sewing speed range for each stitch length. Turn speed control ① to adjust.
- (2) Refer to the table below for allowable sewing speeds.

Stitch length (mm)	Sewing speed (spm)
0.2~3.0	1,000~2,000
3.2~4.4	750~1,500
4.6~6.2	600~1,000
6.4~8.0	600~ 800

7 Using the TEST switch

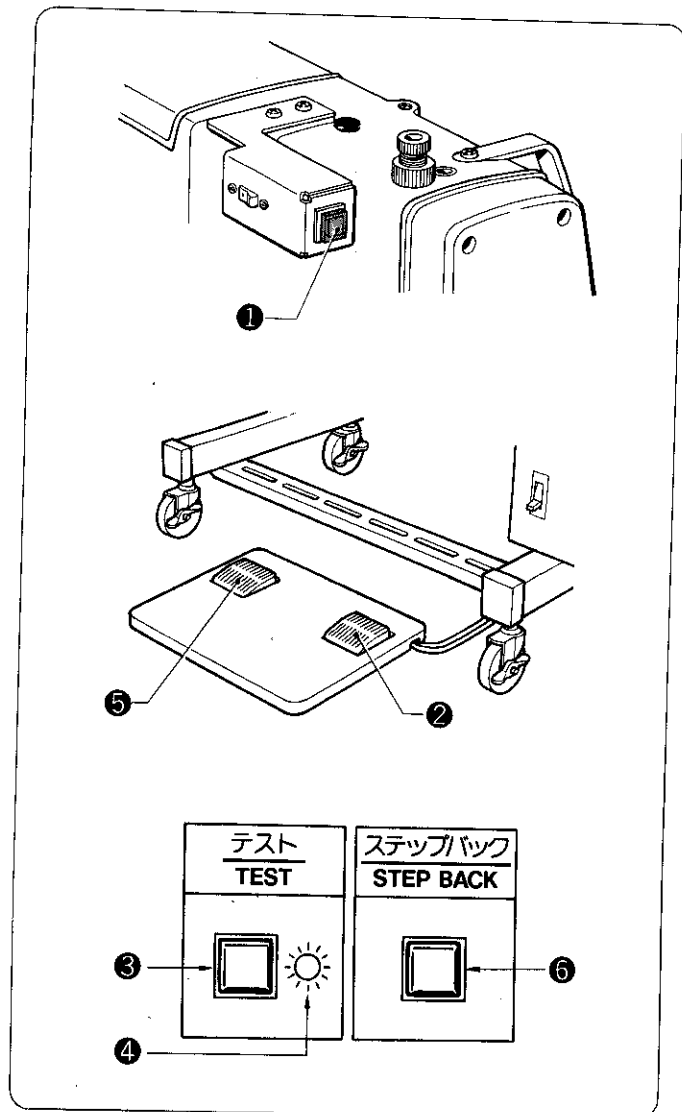

- ★ Use the test switch to begin sewing again from any desired point when the thread breaks or the bobbin thread runs out.
- (1) Press the emergency stop switch ① while the sewing machine is running. (All operations will stop, and an alarm will sound.)
- (2) Press the emergency stop switch ① again. (The thread cutter will operate and the alarm will stop.)
- (3) Press the starting pedal ②.
The work clamp will move automatically to the sewing start position.
- (4) Press the test switch ③. The test indicator ④ will light.
- (5) Press the starting pedal ②. (The needle will remain stationary as the work clamp advances through the pattern at low speed one stitch at a time. Press the presser lifter pedal ⑤ to fast forward.)
- (6) When the work clamp reaches the desired position, press the test switch ③ twice. The work clamp will stop, and the test indicator ④ will go out. If the work clamp was stopped too early, press the test switch ③ again to proceed.
- (7) Sewing will start when the starting pedal ② is pressed.
- ※ The work clamp can be forwarded in 100 stitch units by pressing the step back switch ⑥ when the test switch ③ is on. Also, pressing the step back switch ⑥ after the test switch ③ is turned off will advance the work clamp one stitch at a time. (Press the presser lifter pedal ⑤ to fast forward.)

8 Using the emergency stop switch

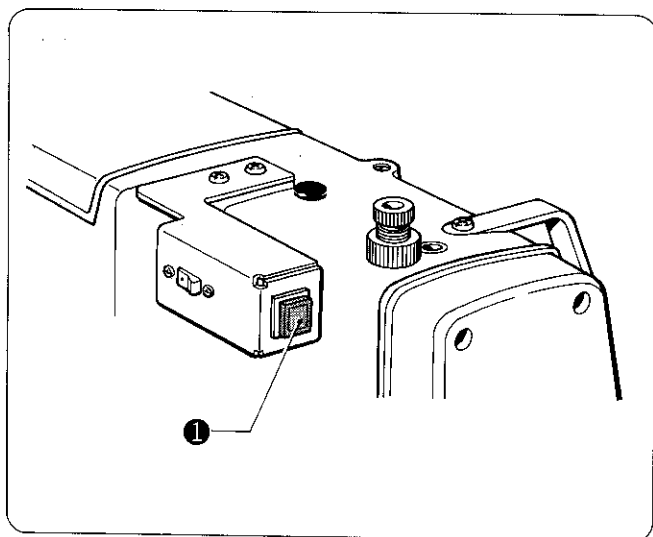

- ★ Press the emergency stop switch to immediately stop the sewing machine during actual sewing or when in the test mode.
- (1) If the emergency stop switch ① is pressed while sewing.
All operations will stop, and an alarm will sound. Correct the problem, and press the emergency stop switch ① again. The thread cutter will operate, the emergency stop function will be cancelled, and the alarm will stop.
- ※ There will be no response when either foot switch is pressed when the emergency stop switch ① is on (the alarm is sounding).
- (2) If the emergency stop switch ① is pressed during the test mode.
All operations will stop, and an alarm will sound. The emergency stop function will be cancelled when the emergency stop switch ① is pressed.

(3) If a problem occurs

If an abnormal load is applied or a problem occurs during sewing, the emergency stop function is automatically activated, all operations stop, and the alarm sounds. Press the emergency stop switch ① to cancel the emergency stop mode.

9 Shifting a stitch pattern

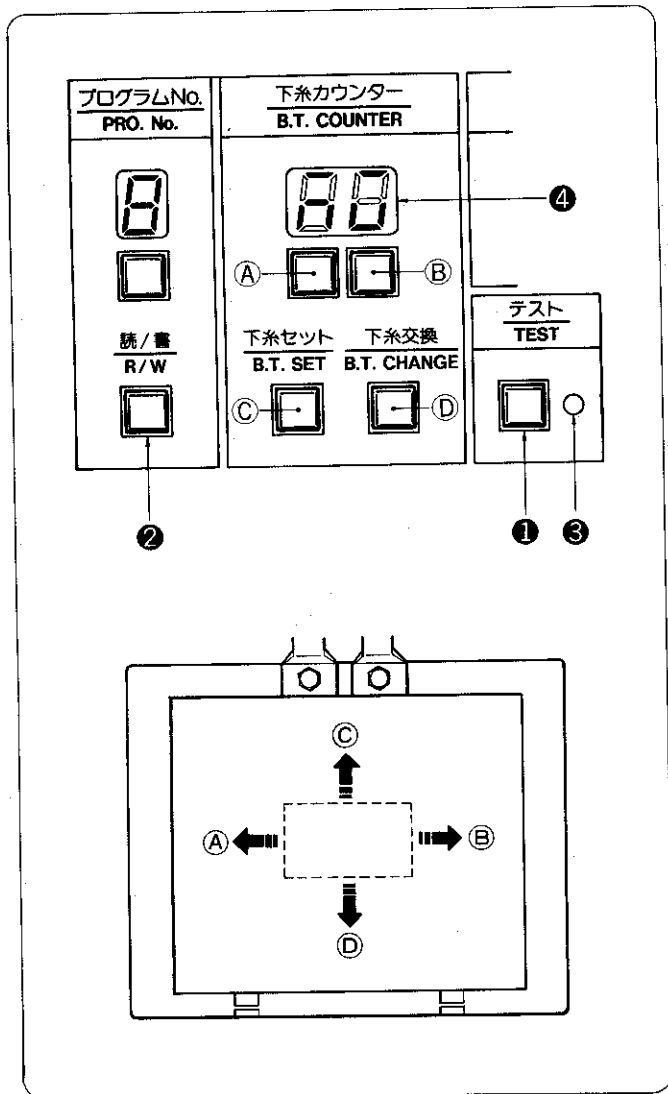

★ The relative position of a previously programmed stitch pattern can be shifted up/down and right/left.

(1) Press and hold the test switch ① and press the R/W switch ②. The test indicator ③ will light, and $\langle \bar{n} \bar{u} \rangle$ will appear in the bobbin thread counter ④.

- ① Press bobbin thread counter switch A to shift the pattern 1 pulse (0.2 mm) left.
- ② Press bobbin thread counter switch B to shift the pattern 1 pulse (0.2 mm) right.
- ③ Press bobbin thread set switch C to shift the pattern 1 pulse (0.2 mm) up.
- ④ Press bobbin thread change switch D to shift the pattern 1 pulse (0.2 mm) down.

(2) After fine adjustment of the pattern position is completed above, press test switch ①. The test indicator ③ and bobbin thread counter ④ will go out, and the stitch pattern shift mode will be cancelled.

SEWING

- (1) Turn the power switch ❶ on. The power indicator on the operation panel will light.
 - (2) Insert the floppy disk ❷.
 - (3) Press the PRO. No. selection switch ❸ to select the desired program number.
 - (4) Press R/W switch ❹.
- (The floppy disk drive indicator will light while the program is being read. An alarm will sound and the indicator will go out when reading is completed.)
- (5) Insert the work piece under the work clamp, and press the presser lifter pedal ❺ to lower the clamp.

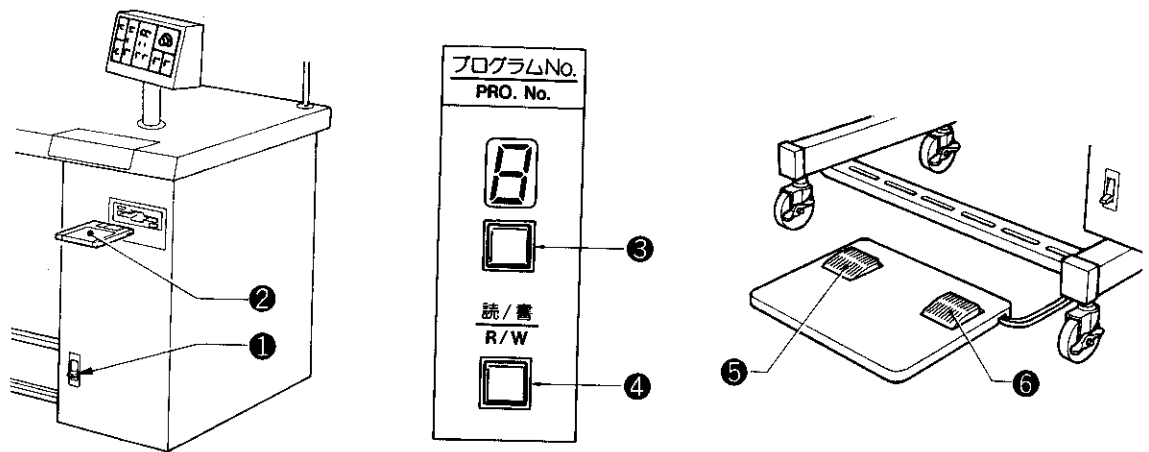

- (6) Press the starting pedal ❻. (The work clamp will return to the origin, and will then advance to the sewing start position.)
- (7) Press the starting pedal ❻ again to start sewing. (This is only required the first time a program is sewn.)
- (8) When sewing is completed, the thread cutter will automatically operate and the work clamp will then rise.

★ Shuttle hook lubrication

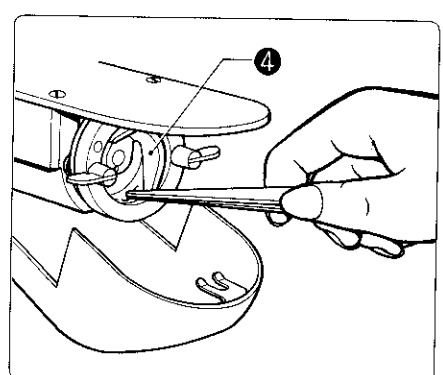
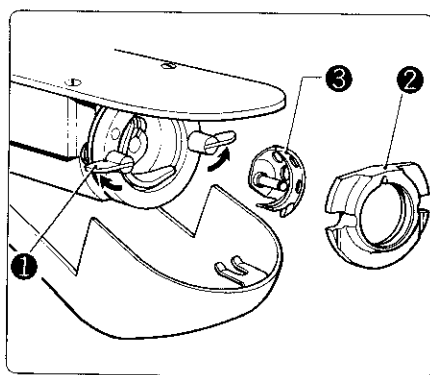
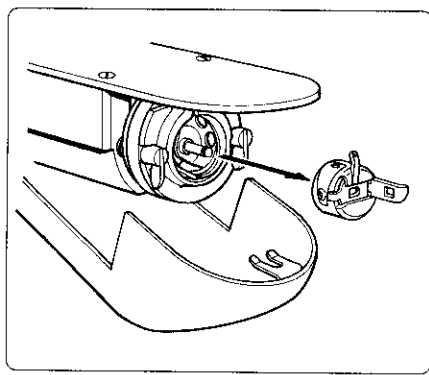

- (1) Pull the shuttle hook cover forward to open, and then remove the bobbin case.
- (2) Slide the tab ❶ in the direction of the arrow, and remove the shuttle race body ❷ and shuttle hook ❸.
- (3) Clean any dust and thread pieces from the driver ❹, the shuttle hook thread guides and race.
After cleaning is completed, add a drop of oil to the race.

STANDARD ADJUSTMENTS

★ Turn the machine pulley by hand when making any adjustments

1 Needle bar height adjustment

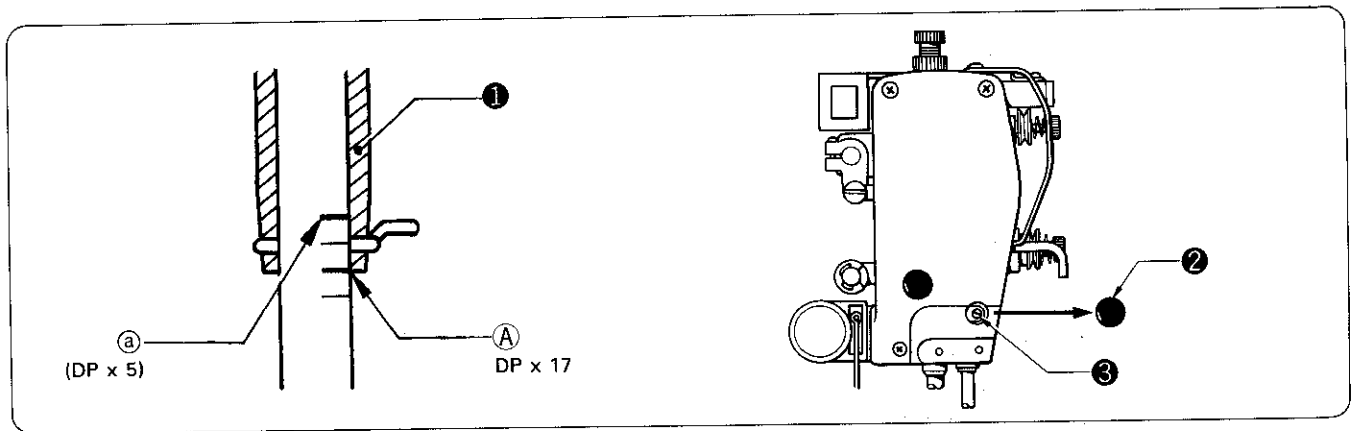

Turn the pulley to completely lower the needle bar. Remove cap **2**, loosen set screw **3**, and vertically adjust the needle bar so that reference line **A**, the second from bottom reference line on the needle bar, is aligned with the bottom of the needle bar bushing **1**.

※ Align the top reference line **a**, with the bottom of the needle bar bushing when using needle DP x 5.

2 Needle bar lift stroke adjustment

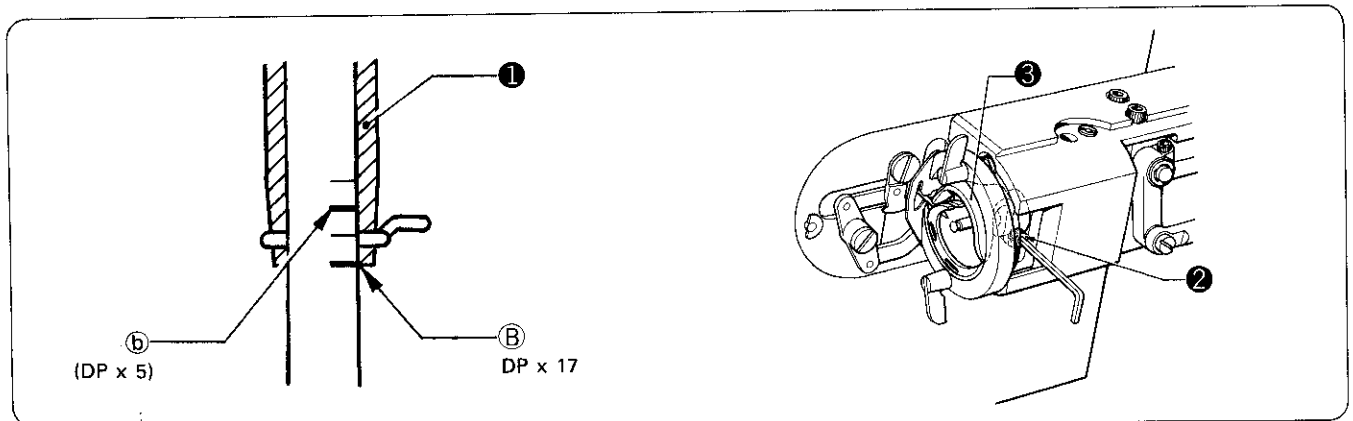

Turn the pulley to raise the needle bar from the lowest needle position and align the bottom reference line **B**, with the bottom of the needle bar bushing **1**. Now, loosen allen screw **2** and turn the shuttle driver so that the shuttle hook point is aligned with the needle center.

※ Align the second from top reference line **b**, with the bottom of the needle bar bushing when using needle DP x 5.

3 Needle to shuttle hook point gap adjustment

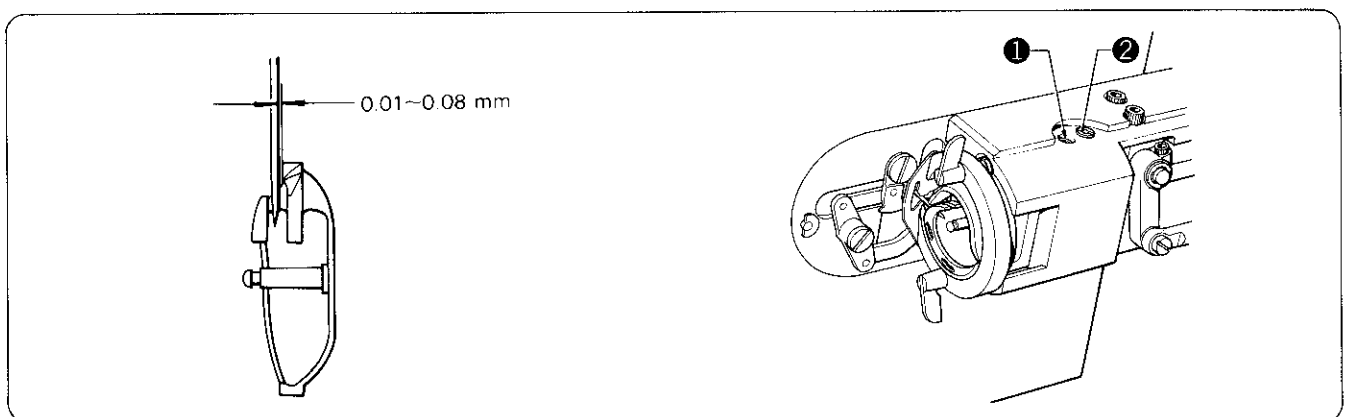

Turn the pulley and align the shuttle hook point with the needle center. Loosen set screw **1** and turn the eccentric connecting link stud **2** to adjust the needle to shuttle hook point gap to 0.01 ~ 0.08 mm.

4 Shuttle driver needle contact adjustment

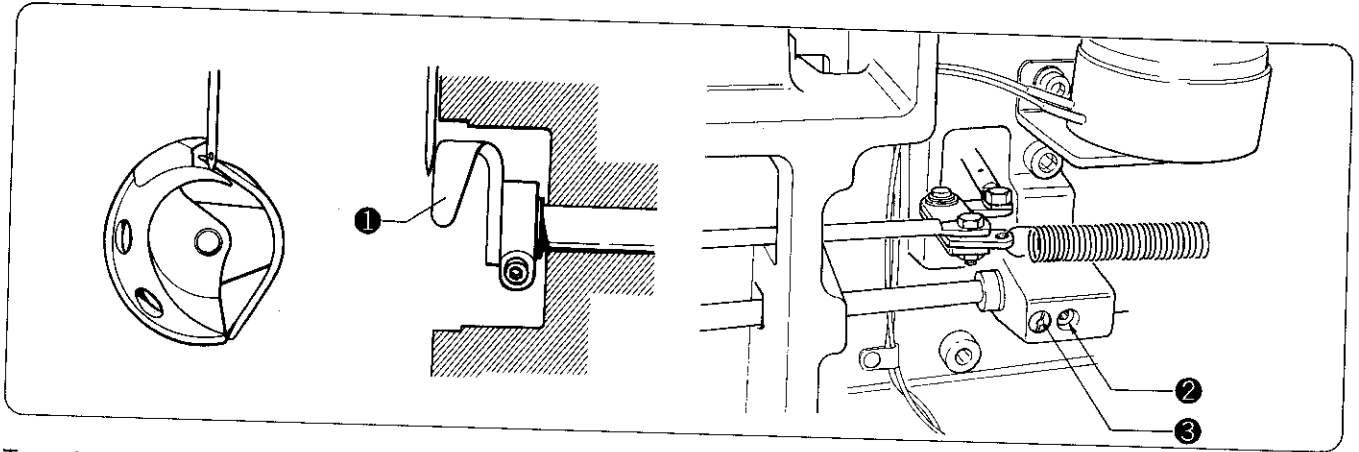

Turn the pulley and align the shuttle hook point with the needle center. Loosen set screw 2 and turn the eccentric connecting link stud 3 so that the needle meets the shuttle driver 1. Note that excessive needle to driver contact will result in skipped stitches. Also, if the needle does not sufficiently contact the shuttle driver, the shuttle hook point will interrupt the needle, resulting in abnormal abrasion.

5 Shuttle hook thread guide adjustment

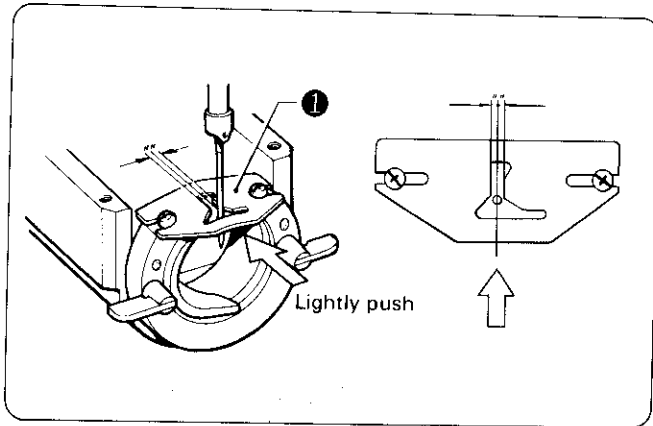

Adjust so that the needle groove of the shuttle hook thread guide 1 is at the center of the needle, slide the thread guide lightly in, and then retighten the screws.

6 Movable knife adjustment

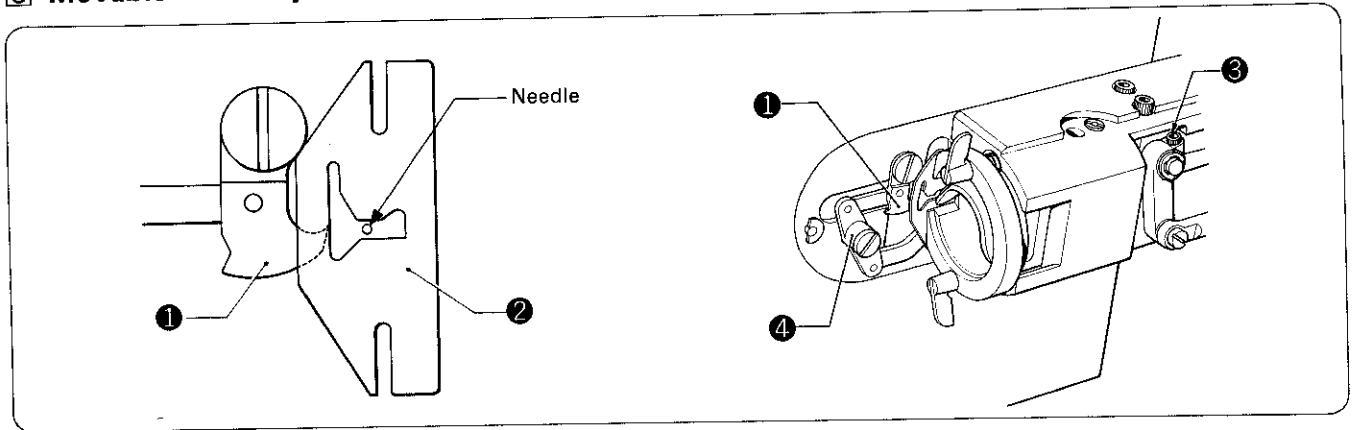

Loosen set screw **3** and adjust the thread cutter connecting rod **4** so that the movable knife **1** tip aligns with the needle groove of the shuttle hook thread guide **2** when the machine is stopped.

<Movable and fixed knife replacement>

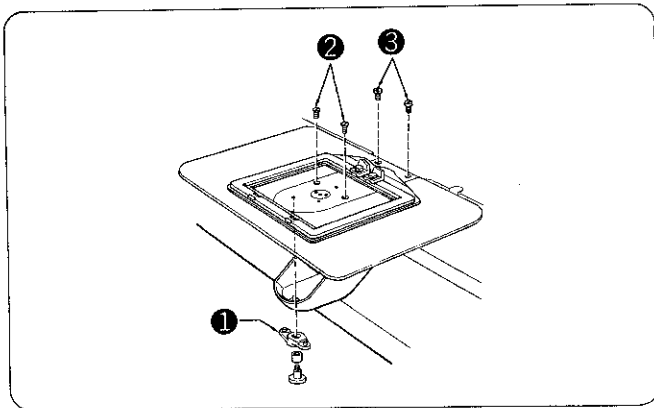

- (1) Open the shuttle race cover.
- (2) Remove the thread cutter connecting rod **1**.
- (3) Remove set screws **2** and flat screws **3**, and remove the needle plate.

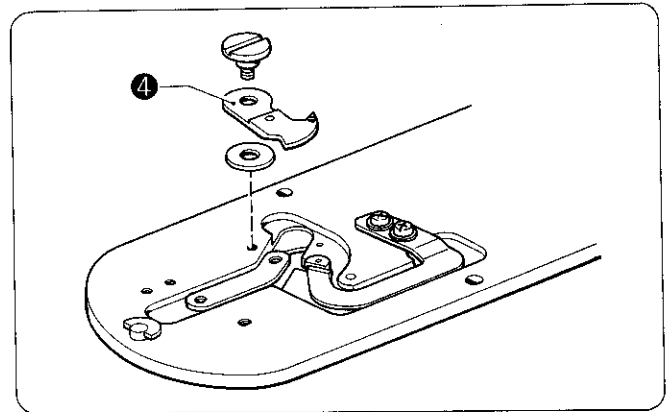

- (4) Remove the movable knife **4** and replace with a new movable knife.

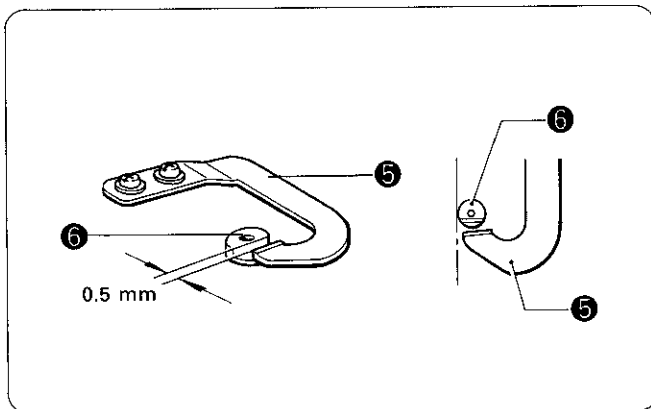

- (5) Remove the fixed knife **5**, and replace with a new fixed knife. Adjust so the needle plate **6** to fixed knife **5** gap is 0.5 mm. Be sure the left side of the fixed knife **5** does not extend beyond the left side of the needle plate.

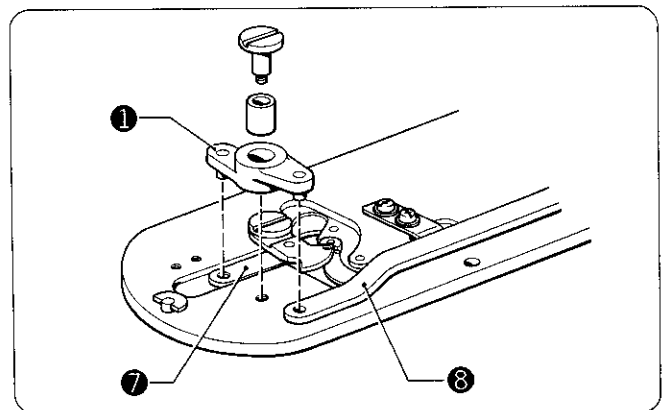

- (6) Set the thread cutter connecting rod **1** pin into the movable knife link **7** and thread cutter connecting rod **8**.
★ Make sure the movable knife is properly aligned after installing the needle plate.

7 Presser foot adjustment

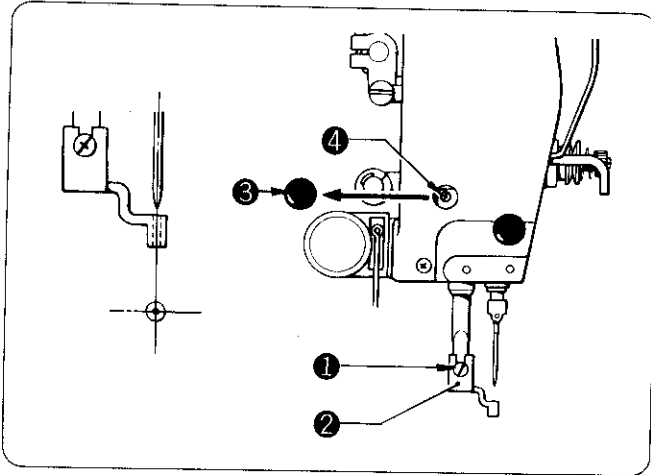

★ Turn the pulley by hand to lower the presser foot to the down position, and then proceed with the steps below.

- (1) Loosen screw ①, set the bottom of the presser foot ② lightly against the work piece, and then tighten screw ①.
- ※ If the presser foot is lowered too far, the work piece will shift when sewing. Also, if the presser foot is too high, skipped stitches may occur.
- (2) Turn the pulley by hand, and make sure the needle enters the center of the needle hole in the presser foot ②. If the needle is not aligned with the center of the needle hole, remove cap ③, loosen screw ④, and turn the presser foot (presser bar) to adjust.

8 Changing the presser foot lift

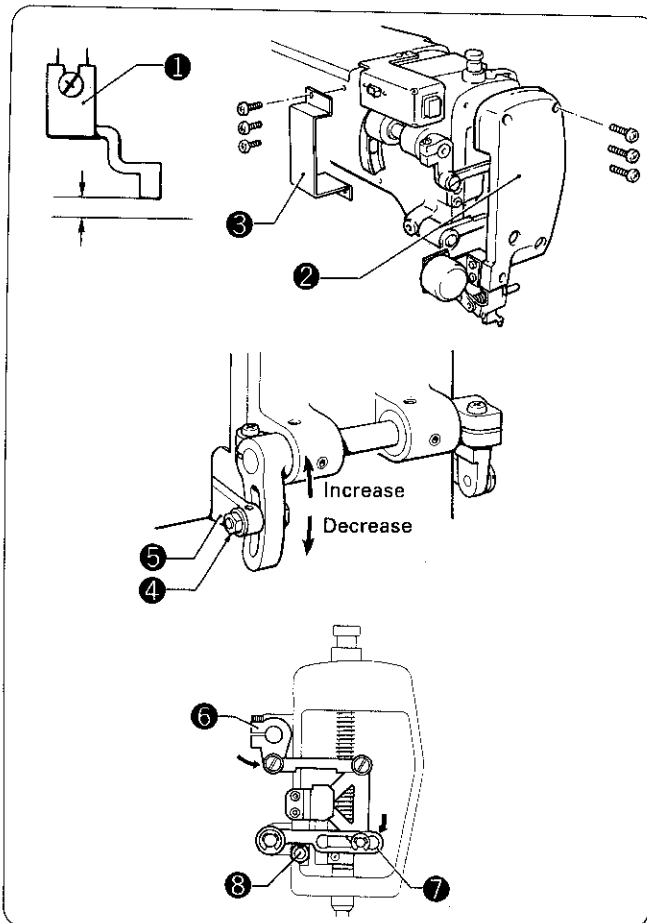

★ Standard vertical presser foot ① stroke is 3.5 mm. (Max. 7 mm)

- (1) Remove intermittent cover ② and face cover ③.
- (2) Loosen nut ④ and change the position of the feed connecting rod ⑤.
 ※ Set to the top position to increase, or the bottom position to decrease the vertical presser foot stroke.
- (3) Turn the pulley to lower the presser foot ①.
- (4) Loosen intermittent feed arm L ⑥, set intermittent supporter ⑦ to stopper ⑧, and tighten intermittent feed arm L ⑥.

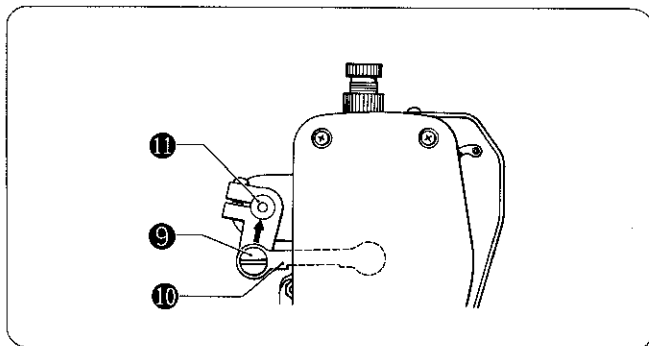

※ If vertical presser foot movement is not necessary, loosen stud screw ⑨, and secure link L ⑩ to the intermittent feed shaft ⑪.

9 Thread wiper adjustment

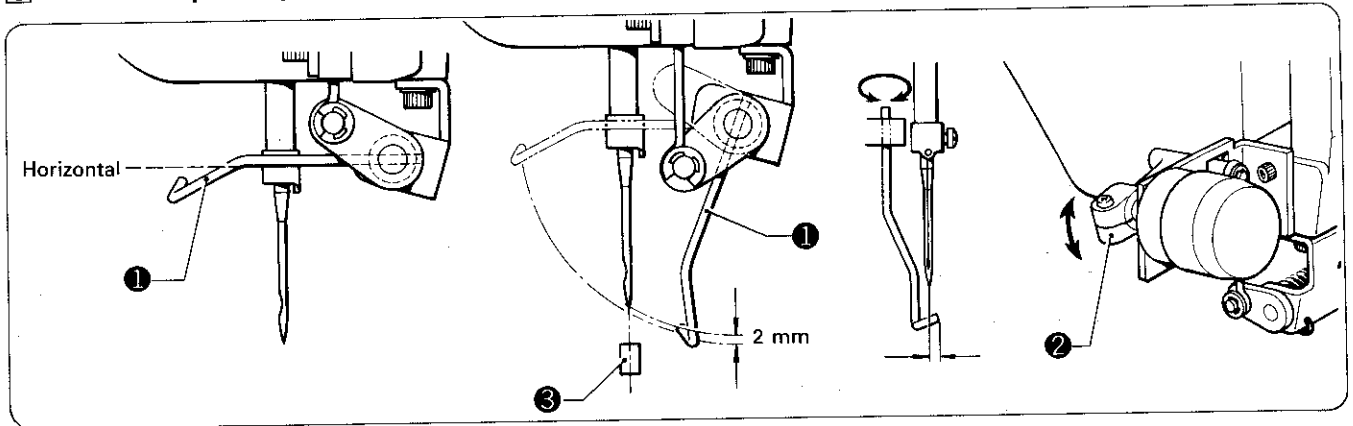

- (1) Adjust the solenoid lever ② so that the thread wiper ① is level when the machine is stopped.
- (2) Work the thread wiper ① so that it is aligned with the center of the needle bar. Slide the wiper ① in or out so that the wiper ① to needle point gap is approximately 2 mm. Be sure the wiper ① does not strike the presser foot ③.

10 Needle and feed timing adjustment

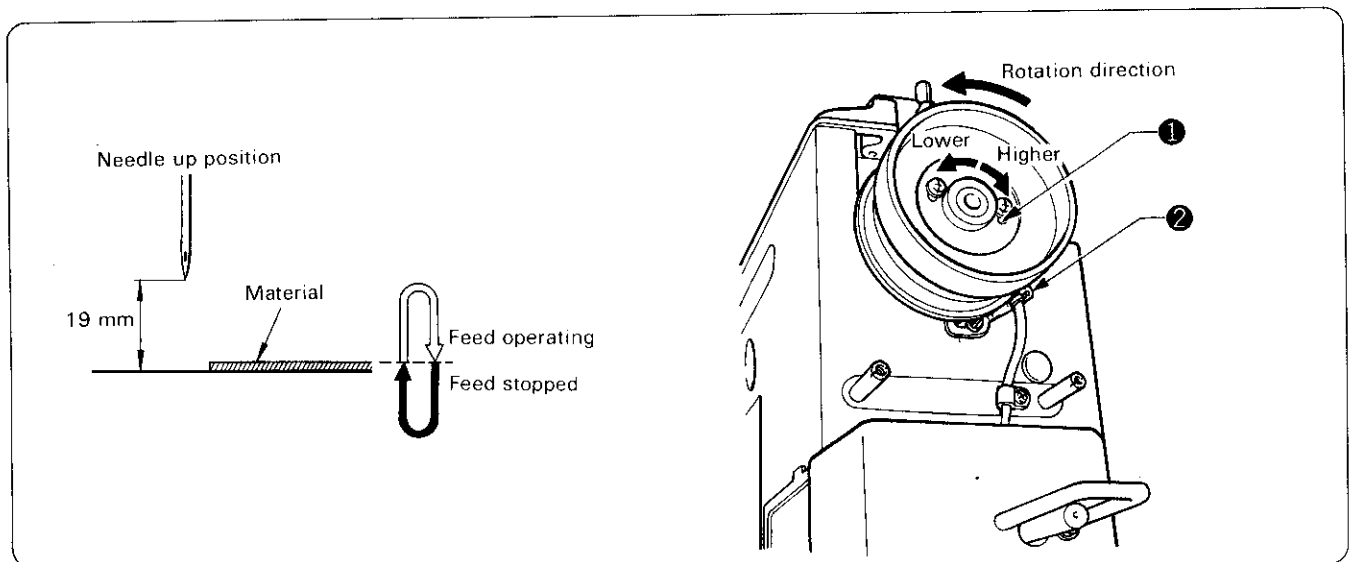

- (1) Adjust reflector ① so that the needle tip is 19 mm above the needle plate when the needle is in the up position. Turn clockwise to raise, counterclockwise to lower the stop position.
- ※ Adjust the needle and feed timing with synchronizer ② so the feed mechanism begins to operate after the needle has been removed from the material, and so that the feed mechanism stops before the needle enters the material.

11 Origin adjustment

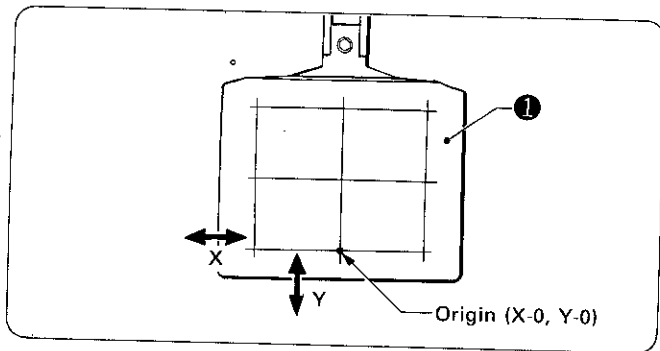

★ The origin is at the middle front. Replace the feed plate with the origin reference plate ① to adjust the origin.

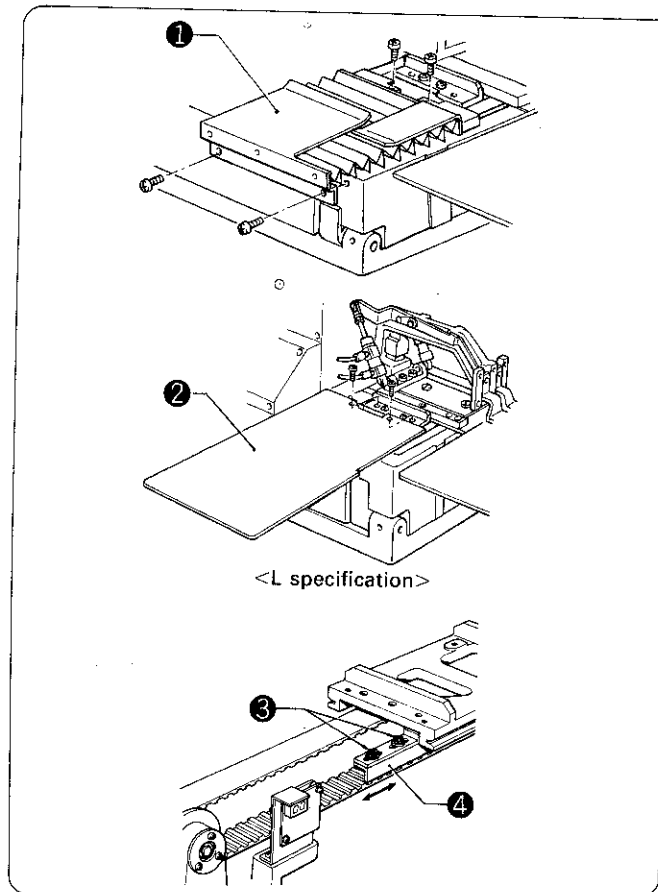

<X-axis>

- (1) Remove sawtooth L ①.
※ On L specification, remove feed cover L ②.
- (2) Loosen set screw ③, and move X-axis origin dog ④ laterally to adjust.

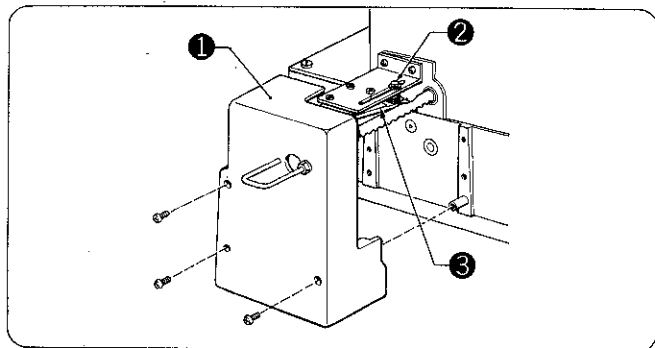

<Y-axis>

- (1) Remove the cover ①.
- (2) Loosen allen bolt ②, and move Y-axis origin dog ③ forward or back to adjust.

12 2-step work clamp operation adjustment

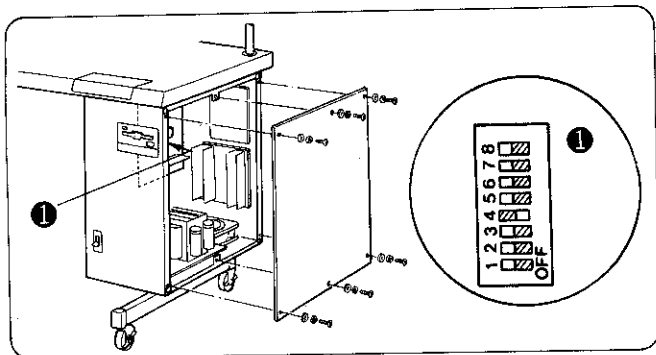

Turn the power off and then open the control box.
 (1) Work clamp motion can be adjusted by adjusting the settings of DIP switch ① <1, 2 and 3> on the control circuit board.



The work clamp will rise automatically when sewing is completed.

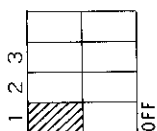

The work clamp will rise when the presser lifter pedal is pressed when sewing is completed.

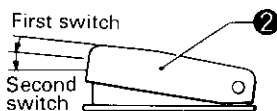
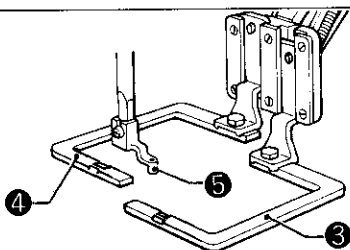

When the presser lifter pedal ② is pressed, work clamp right ③, work clamp left ④, and the presser foot ⑤ will all rise simultaneously. The work clamp (right and left) and the presser foot will appear as below when they descend. (The presser lifter pedal is a two position switch.)

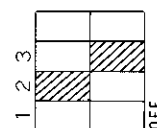

First switch ON: ——— Work clamp left ④ descends.
 Second switch ON: ——— Work clamp right ③ and presser foot ⑤ descend.

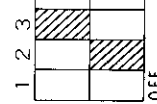

First switch ON: ——— Work clamp right ③ descends.
 Second switch ON: ——— Work clamp left ④ and presser foot ⑤ descend.

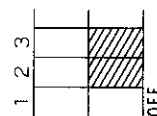

First switch ON: ——— Work clamp right ③ and work clamp left ④ descend.
 Second switch ON: ——— Presser foot ⑤ descends.

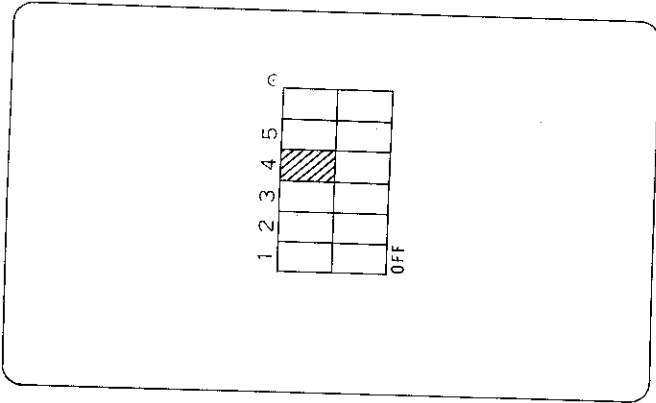

(2) DIP switch ① <4> should be normally ON.

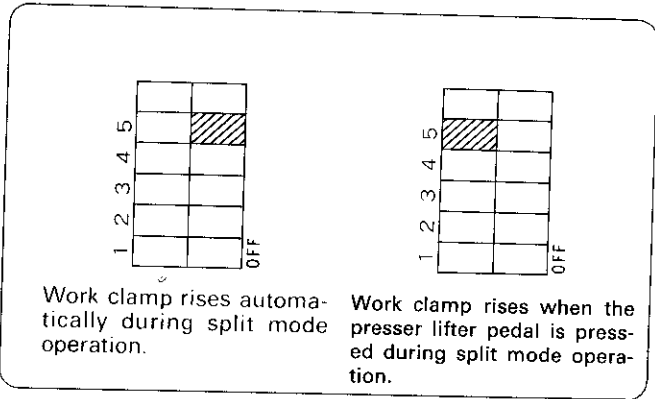

(3) The setting of DIP switch ① <5> determines the operation of the work clamp during split mode operation.

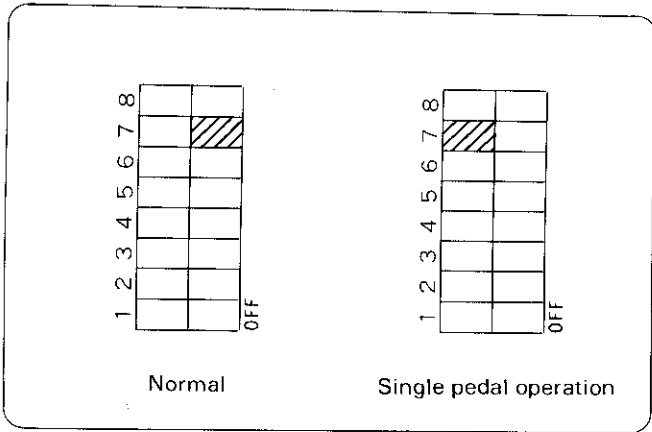

(4) DIP switch ① <7> is used to select single pedal operation.

When the starting pedal is pressed, the work clamp automatically drops, and sewing starts when the switch is released.

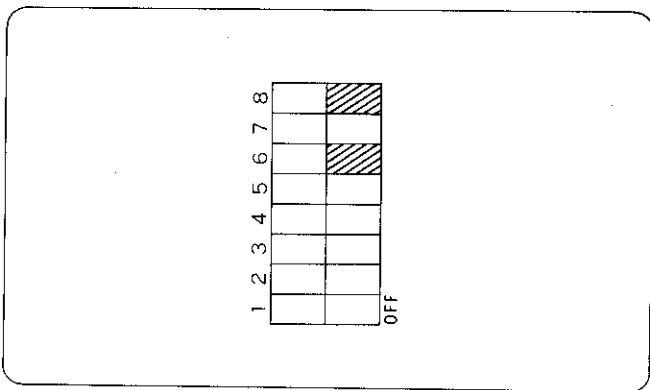

(5) DIP switch ① <6.8> should be off.

OPERATION FLOW CHART

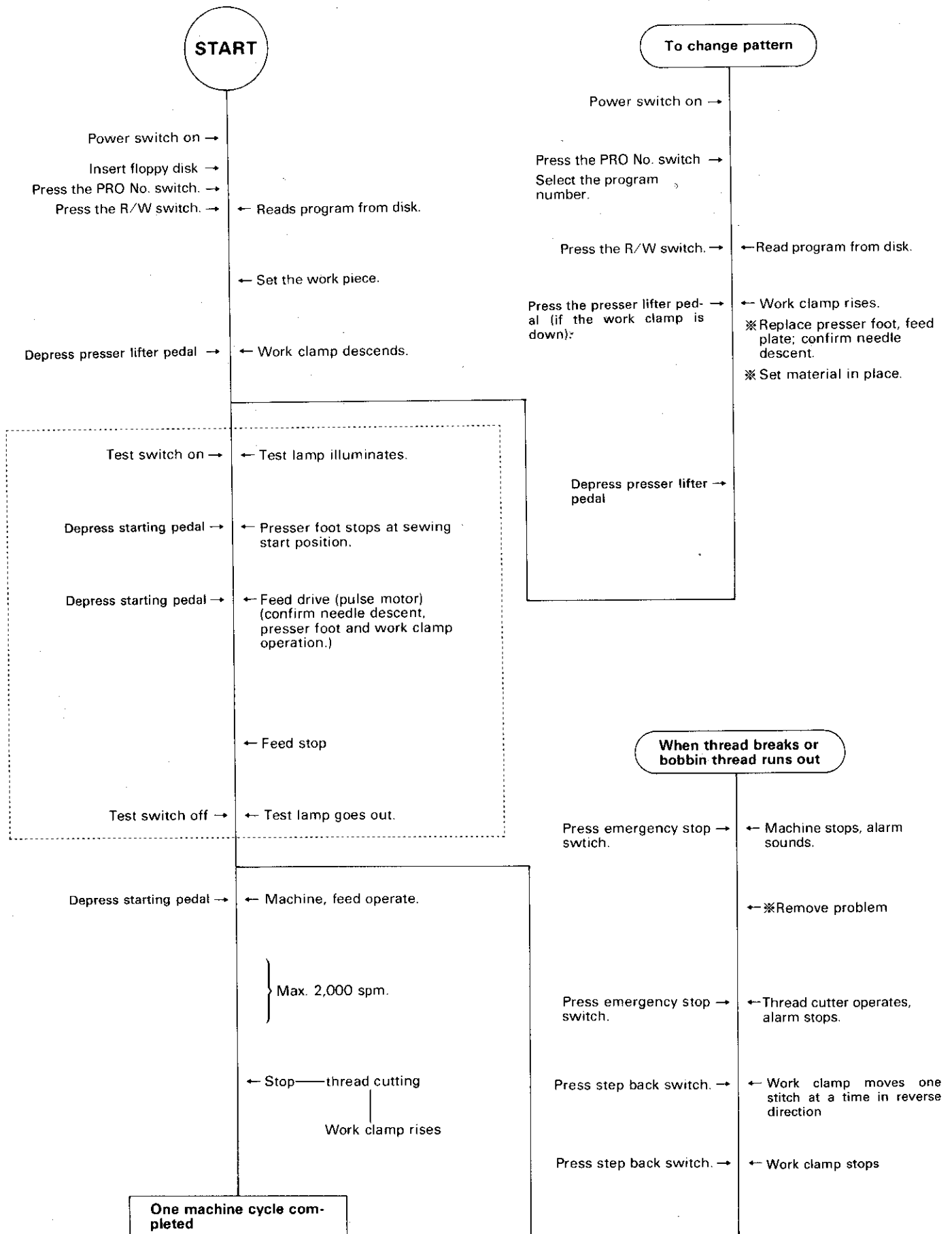

ERROR NO. LIST

NO.	Cause
1	Emergency stop switch pressed
2	Trouble with the motor or synchronizer
3	Ovea-area
4	Floppy disk not inserted, or cable not properly connected
5	Floppy disk is locked (write protected).
6	No program registered
7	Problem with floppy disk drive
8	
9	
A	No usable pattern data on disk

DIP SWITCH SETTINGS

NO.	When ON
1	Work clamp does not rise when sewing completed
2	Pneumatic drive; Left → right two-step work clamp
3	Pneumatic drive; Right → left two-step work clamp
4	Pneumatic drive
5	Work clamp does not rise during split mode operation.
6	Inner clamping drive
7	Single pedal operation possible using the starting pedal
8	

