

brother.

ELECTRONIC PROGRAMMABLE PATTERN TACKER PROGRAMMER

bro rom
INDUSTRIAL MACHINES

Str. Fabrica de Glucoza 2-4, sector 2, Bucuresti, Romania
Nr. Reg. Com.: J 40/5796/1997, C.U.I.: R9645361
Tel./Fax: +01 2323.844, +01 232.969, +01 2323.87
Www.brother.ro www.broram.ro email:office@brother.ro

BAS-326

INSTRUCTION MANUAL

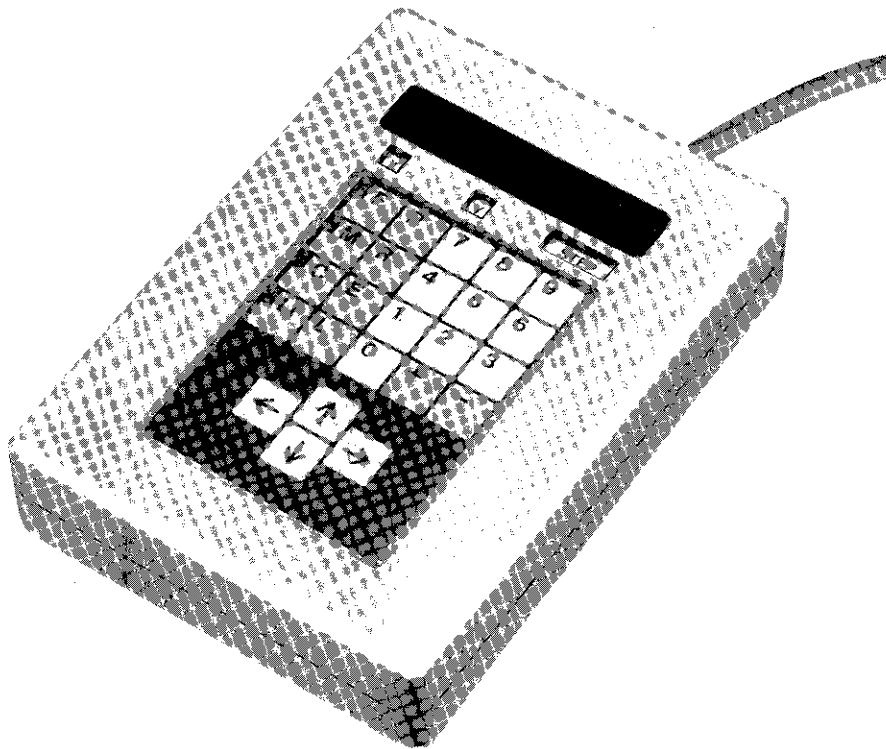

CONTENTS

EXPLANATION OF THE KEYBOARD AND DISPLAY	1
COMMAND LIST	3
HOW TO USE THE PROGRAMMER	3
PROGRAMMING PROCEDURE	4
1 Preliminary procedure	4
2 To program the pattern one stitch at a time	5
3 To program with the enlarged input mode	5
4 To program a stitch pattern containing numerous straight lines in the pattern design	6
5 To program with the smoothing function	7
6 To program a double stitch patterns	9
7 To program an intermittent stitch sewing operation	10
8 To program a basting stitch	11
9 To program a symmetrical mirror image of a pattern design	12
10 To input a split program	14
11 Split sewing without intermediate thread trimming	15
12 To program a low speed sewing operation in subdivided sections	16
13 To program a stitch pattern by tracing the design	17
14 To program a design with recurring patterns	18
15 To program a zigzag sewing operation	19
16 To program enlargement/reduction patterns	23
17 If a command key is pressed accidentally	23
HOW TO WRITE DATA TO DISK	24
1 To write program data to disk	24
HOW TO REVISE THE PROGRAM	25
1 To revise a section of a stitch pattern program from points according to alterations made in the stitch pattern design	25
2 To cancel the initial stitch of a stitch pattern which has already been programmed	26
3 To cancel the initial stitch of a pattern and reprogram the newly-established initial stitch position	26
4 To program a sewing operation prior to the initial stitch position of the pattern which has already been programmed	27
5 To program a shunting point prior to the initial stitch position of the pattern which has already been programmed	27
6 To shift the shunting point from point A to point B	28
7 To cancel the shunting point A	28
8 To parallel-shift a programmed stitch pattern in the X axis or Y axis	29
9 To cancel points 7 and 8 after locating an error in the program	30
10 To shift a pattern B that is in the middle of consecutively programmed patterns	30
11 To set a constant sewing speed irrespective of stitch length	30
12 When thread trimming is not used at the sewing end	31
HOW TO USE AND MAINTAIN THE FLOPPY DISK	32

EXPLANATION OF THE KEYBOARD AND DISPLAY

X/Y display

This display indicates the amount of work clamp movement in the X-axis or Y-axis when the feed key is pressed.

Command indicator

The command indicator will illuminate when the feed key, mirror key, cancel key, or line key is pressed, i.e., only if they are operating properly.

Feed key

After the thread trimming operation is completed this key is to be used if the sewing operation is not to be restarted immediately following the position at which the thread trimming operation was performed.

Mirror key

This key is to be used to program a symmetrical mirror image of a pattern design which has already been input or to program a turning pattern design. It is also to be used to perform such operations as enlarging/reducing.

Cancel key

This key is to be used to cancel any of the points in the pattern design which has already been programmed.

Line key

This key enables the operator to easily program the straight-line portion of the pattern design.

Direction keys

When these keys are pressed, the position of the needle will move in the direction indicated by the arrow.

However, if the command indicator "F", "M" or "LI" is not displayed, the position of the needle will not move more than 8.0 mm.

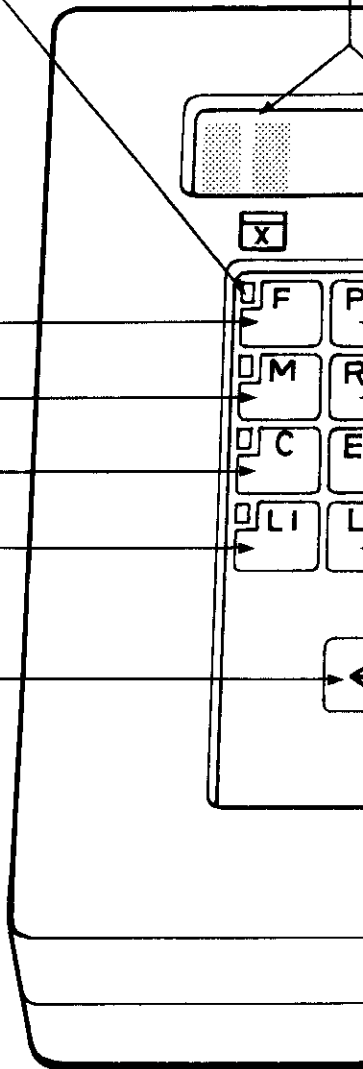

STEP display

- This display indicates the number of steps when the **+** key or **-** key is used.
- It also indicates the various numerical input commands.
- If the programmable sewing speed becomes less than 500 spm while in the (**L**) mode, the display will flash on and off up to 100 spm to warn the operator.

Program key

This switch is to be used to select either the sewing mode or the program mode.

Reset key

If this key is pressed during the program mode, the presser clamp will move to the point of origin. Furthermore, if "222" is displayed in the STEP display and the **R** key is pressed, the program will be erased completely.

End key

Upon completion of a program, if "111" is displayed on the STEP display and the **E** key is pressed, the termination of the stitch pattern will be programmed.

Load key

If this key is pressed, the position of the needle at that time will be programmed.

Note that even if this key is pressed more than once while the needle is maintained in the same position, the input command will be programmed only once.

Minus key

- When this key is pressed, the work clamp will move in reverse of the program direction as many steps (i.e., the number of times the **L** key is pressed) indicated on the STEP display.
- If any input command key is pressed accidentally, this key can be used to clear the command.

Plus key

- When this key is pressed, the work clamp will move in the program direction as many steps (i.e., the number of times the **L** key is pressed) indicated on the STEP display.
- If any input command key is pressed accidentally, this key can be used to clear the command.

Numeral keys

When these keys are pressed, they will be indicated on the display in sequential order below the STEP display.

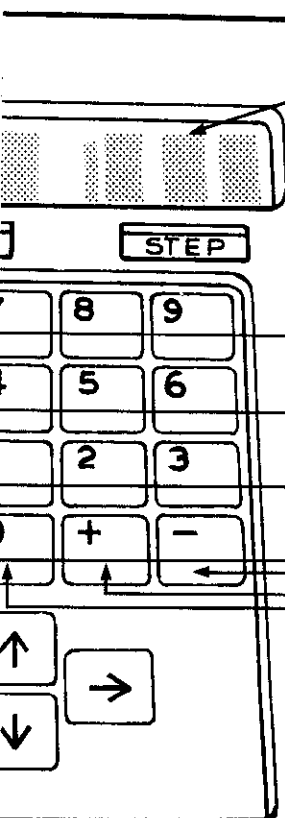

COMMAND LIST

- This command list is to be used to program an operation. Refer to this list to input the program correctly.

111 <input type="checkbox"/> E	END	<input type="checkbox"/> F	666	SPLIT PROGRAMS
222 <input type="checkbox"/> R	DATA CLEAR	<input type="checkbox"/> F	777	HORIZONTAL MOVEMENT IN MID-PROGRAM
333 <input type="checkbox"/> L	REPEAT	<input type="checkbox"/> F	888	SPLIT PROGRAMS WITH NO THREAD TRIMMING
555 <input type="checkbox"/> L	TRACE	<input type="checkbox"/> F	999	BASTING PROGRAMS
666 <input type="checkbox"/> L	LOW SPEED	888 <input type="checkbox"/> M		EXPANSION/CONTRACTION MODE SPECIFICATION
440 <input type="checkbox"/> L	POINT SYMMETRY	<input type="checkbox"/> <input type="checkbox"/> <input type="checkbox"/> <input type="checkbox"/> <input type="checkbox"/> F		EXPANSION/CONTRACTION MODE RATIO SPECIFICATION
441 <input type="checkbox"/> L	X SYMMETRY			
442 <input type="checkbox"/> L	Y SYMMETRY	<input type="checkbox"/> <input type="checkbox"/> <input type="checkbox"/> <input type="checkbox"/> <input type="checkbox"/> M		EXPANSION/CONTRACTION MODE RATIO SPECIFICATION
443 <input type="checkbox"/> L	REVERSE			
001 <input type="checkbox"/> M	ORIGINAL	<input type="checkbox"/> <input type="checkbox"/> <input type="checkbox"/> M		Smoothing (Set pitch, ex.: for 3 mm pitch, enter 030 <input type="checkbox"/> M .)
011 <input type="checkbox"/> M	010 <input type="checkbox"/> M	789 <input type="checkbox"/> L		Smoothing terminate, be to sure enter at every corner.
		2 <input type="checkbox"/> <input type="checkbox"/> <input type="checkbox"/> M		Double stitch command (Set width, ex.: for 2 mm width, enter 220 <input type="checkbox"/> M .)
		9 <input type="checkbox"/> <input type="checkbox"/> <input type="checkbox"/> M		Enlarged input command (Set enlargement ratio; ex.: to double the size, enter 902 <input type="checkbox"/> M .)

HOW TO USE THE PROGRAMMER

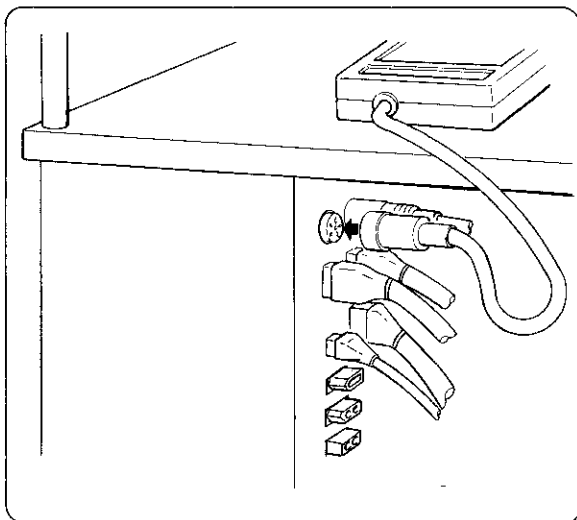

- (1) Connect the cord of the programmer to the terminal in the control box.
- (2) Turn the power on, and then press the P key (program key) to enter the program mode.
- (3) When programming is completed, press the P key again to cancel the program mode and enable sewing.

PROGRAMMING PROCEDURE

1 Preliminary procedure

- (1) Outline the pattern of the needle movement on a piece of graph paper.
At this time, be sure to use a thin piece of graph paper.
Tape the pattern of the needle path to the feed plate so that it will not move.

«Note»

- Outline the pattern design to actual size. (If an enlarged pattern is used, draw the pattern to 2, 5, or 10 times actual size.)
- Design the pattern in such a way that the stitch length does not exceed 8.0 mm in either the X- or Y-axis.
- The maximum spm is 2,000.
- The maximum pattern size is 150 mm in the X-axis and 100 mm in the Y-axis. (180 mm (X-axis) × 100 mm (Y-axis) on Large specification.)
- There are no limits in establishing the initial stitch position, performing a backstitch operation, or setting the sewing direction.

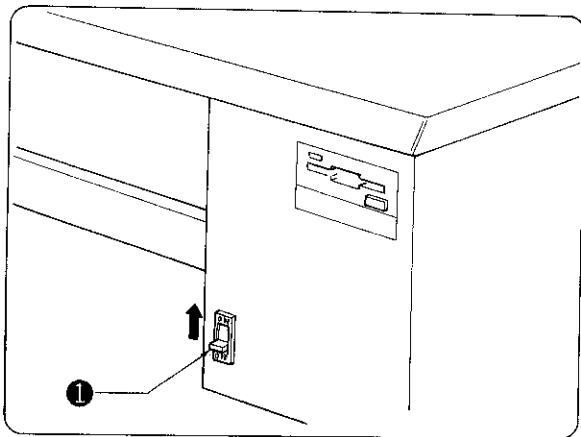

- (2) Turn the power switch ❶ on.

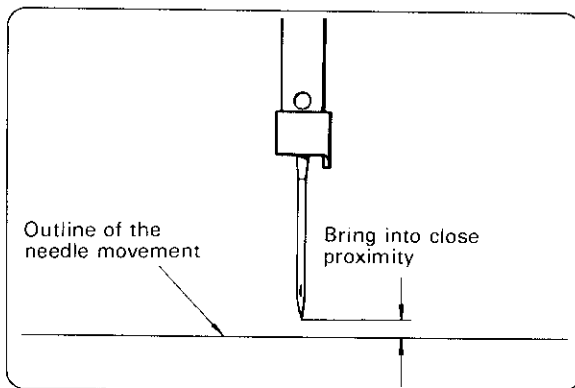

- (3) Manually rotate the pulley to move the needle point along the stitch pattern.

☆ Cautions on sewing

- The sewing speed of this machine is automatically regulated according to the stitch length. The relationship between stitch length and sewing speed is shown in the table below.

Stitch length	Sewing speed
0.2 ~ 3.0 mm	1,000 ~ 2,000 spm
3.2 ~ 4.4 mm	750 ~ 1,500 spm
4.6 ~ 6.2 mm	600 ~ 1,000 spm
6.4 ~ 8.0 mm	600 ~ 800 spm

2 To program the pattern one stitch at a time

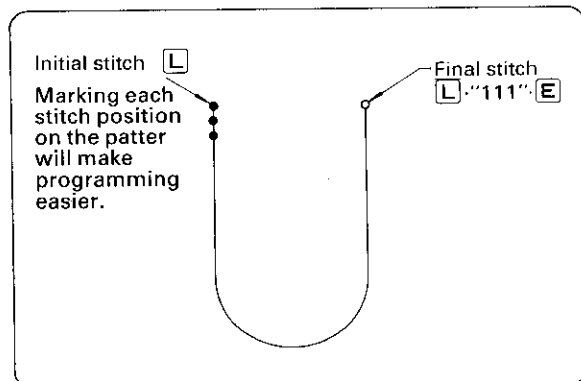
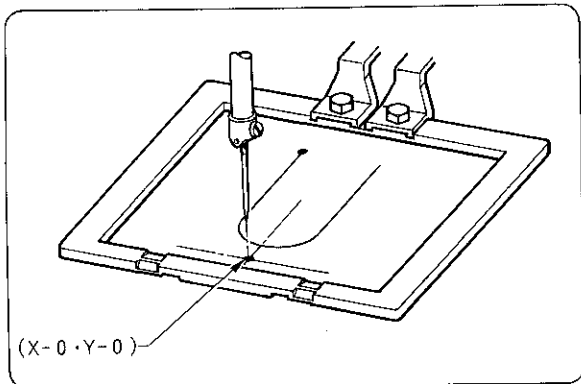

Example: Program the pattern in the figure at left.

- (1) Press the **[P]** key. The work clamp will move to the point of origin (X-0; Y-0), the numeral "0" will be indicated on the STEP display, and the command indicator "F" will illuminate.
- (2) Operate the direction keys to move the work clamp to the initial stitch position.
- (3) When the tip of the needle and the initial stitch position on the outline of the needle movement become aligned, press the **[L]** key. Thus, the initial stitch will be programmed.
- (4) Repeat the above procedure to program the remaining stitches of the pattern.
- (5) After the **[L]** key is pressed to program the final stitch, press the numeral key **[1]** 3 times to indicate "111" on the STEP display, and then press the **[E]** key.
- (6) The work clamp will move back to the initial stitch position.
- (7) Press the R/W switch to write the pattern to disk. (Refer to page 24.)
- (8) Press the **[P]** key.

3 To program with the enlarged input mode

- Programming a fine pattern stitch by stitch is simplified by enlarging the pattern and entering it with the enlarged input mode.

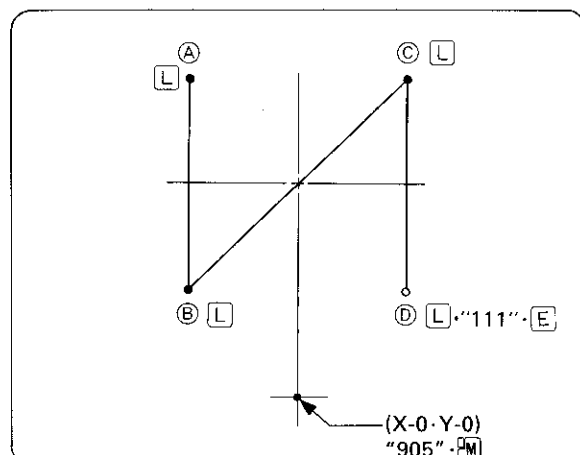
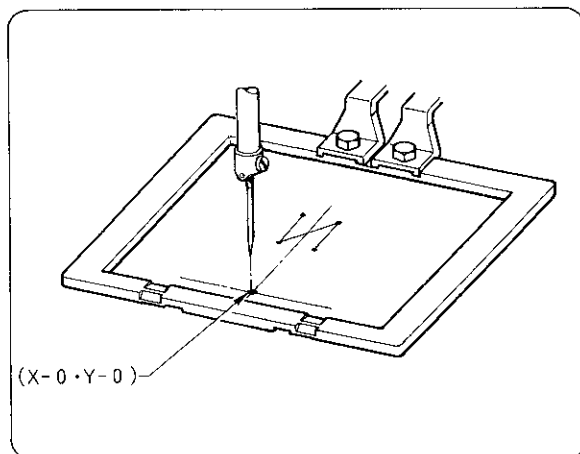

Example: Program the pattern below with a 5-times enlargement of the actual pattern.

- (1) Prepare the pattern used for programming. (This should be a 500% enlargement (based on the center point of the work clamp) of the actual pattern.)
- (2) Press the **[P]** key. The work clamp will move to the point of origin (X-0, Y-0), "0" will appear in the STEP display, and command indicator "F" will light.
- (3) Use the numerical keypad to display 9 **[] []** in the STEP display. The last two digits entered are the enlargement ratio, which can be set for 2, 5, or 10 times. As a 5-times enlargement is being used, the display should read "905".
- (4) Press the **[M]** key.
- (5) Use the direction keys to position the needle at sewing start position the **(A)** on the pattern, and then press the **[L]** key.
The first stitch is now programmed.
- (6) Use the direction keys and **[L]** key to program each of the successive points **(B)** through **(D)**.
- (7) After pressing the **[L]** key at **(D)**, press numeral key **[1]** three times. Confirm that "111" is in the STEP display, and then press the **[E]** key.
- (8) The work clamp will return to the initial stitch position.
- (9) To check the program, press key **[9]** three times to display "999" in the STEP display, and then press the **[+]** key. The work clamp will move stitch by stitch through the pattern starting at the initial stitch position.
- (10) Press the R/W switch to write the pattern to disk. (Refer to page 24.)
- (11) Press the **[P]** key.

4 To program a stitch pattern containing numerous straight lines in the pattern design

- To program the straight-line portions of the pattern design, use the **[L]** key (Line key) to facilitate the programming operation.

Example: Program the pattern in the figure below.

- (1) Press the **[P]** key. The work clamp will move to the point of origin (X-0; Y-0), the numeral "0" will be indicated on the STEP display, and the command indicator "F" will illuminate.
- (2) Operate the direction keys to move the work clamp to the initial stitch position.
- (3) When the tip of the needle and the initial stitch position **(A)** on the outline of the needle movement become aligned, press the **[L]** key. Thus, the initial stitch will be programmed.

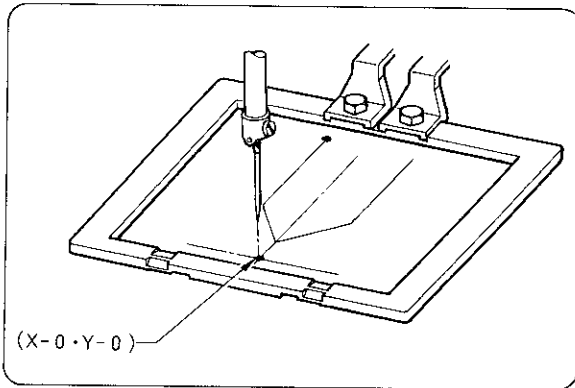

- (4) Operate the numeral keys to indicate the proper pitch on the STEP display.

(For example, to set the proper stitch length when the actual stitch length is 3 mm, use the numeral keys to indicate "030" on the STEP display.)

- * If the pitch is not indicated on the STEP display, or if it exceeds 8.0 mm "080", it will automatically be set to 2 mm.

- (5) Press the **[L]** key. The command indicator "LI" will illuminate.

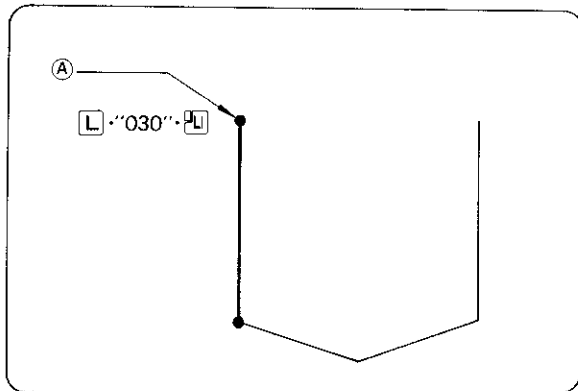

- (6) Use the direction keys to move the work clamp to the final stitch position **(B)** on the straight line portion of the pattern design.

Note 1 When more than 120 stitches are required between point **(A)** and point **(B)**, the operation speed of the work clamp will suddenly decrease to warm the operator.

Therefore, press the **[L]** key and then the **[LI]** key between point **(A)** and point **(B)** to reprogram the remaining stitches on the straight-line portion of the pattern design.

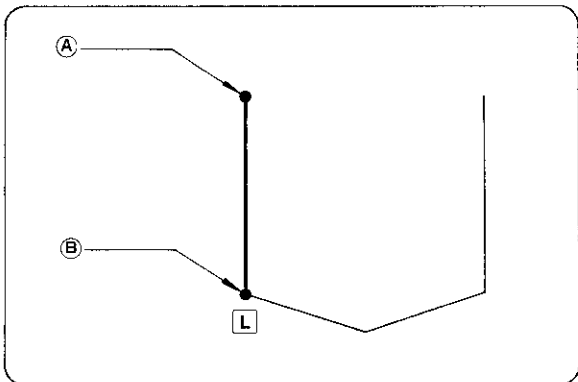

- (7) Press the **[L]** key when the tip of the needle becomes aligned with point **(B)** on the outline of the needle movement. Thus, the straight-line portion from point **(A)** to point **(B)** will be programmed.

- (8) Repeat the above procedure to program the remaining straight-line portions from point **(B)** → **(C)**, **(C)** → **(D)**, **(D)** → **(E)**.

Note 2 For diagonal lines, e.g. **(B)** → **(C)**, **(C)** → **(D)**, there are instances in which the line may not turn out to be straight unless the line is subdivided into smaller portions.

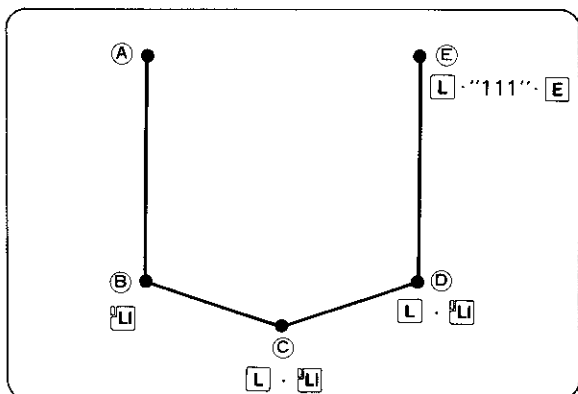

- (9) Press the **[L]** key at the position indicated by the letter **(E)**. Then, press the numeral key **[1]** 3 times to indicate "111" on the STEP display, and then press the **[E]** key.

- (10) The work clamp will move back to the initial stitch position.

- (11) Press the R/W switch to write the pattern to disk. (Refer to page 24.)

- (12) Press the **[P]** key.

5 To program with the smoothing function

- Curved line patterns can be programmed more simply using the numerical keypad and the $\square M$ key instead of programming stitch by stitch.

Example: Program the pattern in the figure below.

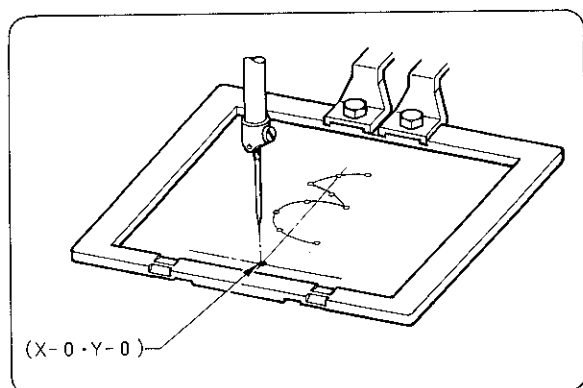

- (1) Press the $\square P$ key. The presser clamp will move to the point of origin (X-0, Y-0), "0" will appear in the STEP display, and command indicator "F" will light.
- (2) Use the direction keys to move the work clamp to the initial stitch position.

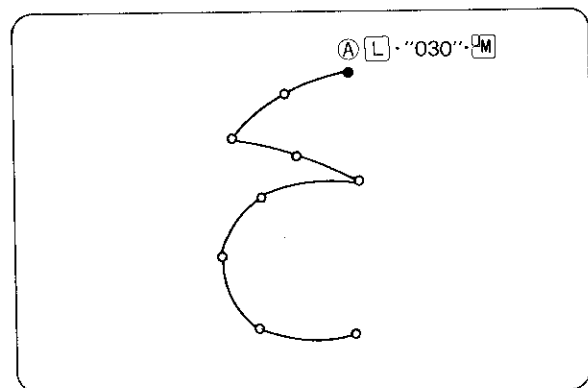

- (3) Use the direction keys to position the needle at sewing start position \textcircled{A} on the pattern, and then press the $\square L$ key. The first stitch is now programmed.
- (4) Use the numeral keys to enter the stitch length in the STEP display. (e.g., if the stitch length is 3 mm, "030" should be displayed.)
 - ※ If the stitch length is not specified, or if a stitch length greater than 8.0 mm ("080" in the STEP display) is entered, it will be automatically be reset to 2 mm.
- (5) Press the $\square M$ key. Command indicators "F" and "M" will be on.

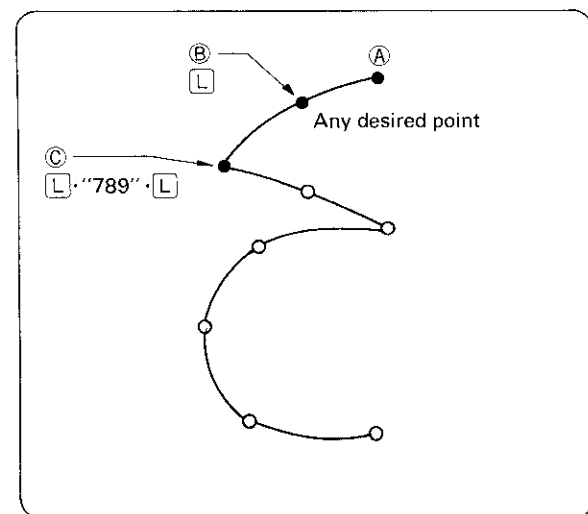

- (6) Use the direction keys to move to point \textcircled{B} , and then press the $\square L$ key. Point \textcircled{B} is now programmed.
- (7) Use the direction keys to move to point \textcircled{C} , and then press the $\square L$ key. Point \textcircled{C} is now programmed.
- (8) At corners such as \textcircled{C} , as the pattern should be broken. Display "789" in the STEP display, and press the $\square L$ key. An electronic alarm will beep, indicating the pattern is being processed. This completes programming of interval $\textcircled{A} \sim \textcircled{C}$.

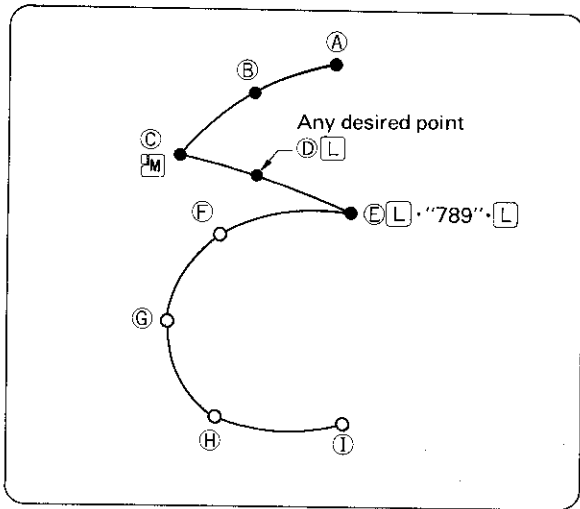

- (9) Press the **PM** key. (If the stitch length is to be changed, specify the new stitch length before pressing the **PM** key.)
- (10) Use the direction keys to move to points **D**, and then press the **L** key. Point **D** is now programmed.
- (11) Use the direction keys to move to point **E**, and then press the **L** key. Point **E** is now programmed.
- (12) As in step (8), display "789" in the STEP display, and press the **L** key. This completes programming of interval **C** ~ **E**.

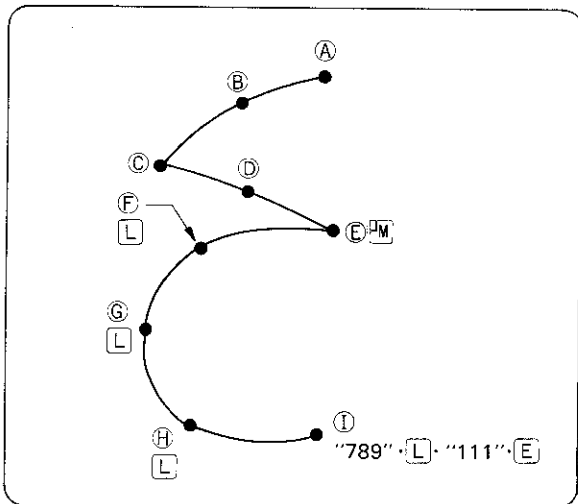

- (13) Press the **PM** key. (if the stitch length is to be changed, specify the new stitch length before pressing the **PM** key.)
- (14) Use the direction keys and the **L** key to program points **F**, **G** and **H**.
- (15) As in step (8), at the last point **I** display "789" in the STEP display, and press the **L** key. This completes programming of interval **E** ~ **I**.
- ※ Programming can also be continued from point **I** after step (15).
- (16) Press numeral key **I** three times. Confirm that "111" is in the STEP display, and then press the **E** key.
- (17) The work clamp will return to the initial stitch position.
- (18) Press the R/W switch to write the pattern to disk.
(Refer to page 24.)
- (19) Press the **P** key.

- Note 1** At corners such as **C** and **E**, be sure to break the pattern. If the pattern is not broken, these corners will also be rounded by the smoothing function.
- Note 2** Using as many intermediate points (**B**, **D**, **F**, **G**, **H** in the figure) as possible will provide better results.

6 To program double stitch patterns

- Programming a pattern with two seams at a constant width apart can be easily accomplished with smoothing.
- When sewing a double seam pattern as shown below, the second seam will be sewn to the left of the base (main) pattern line. It is therefore necessary to consider and determine the base line of the pattern to obtain the desired effect.

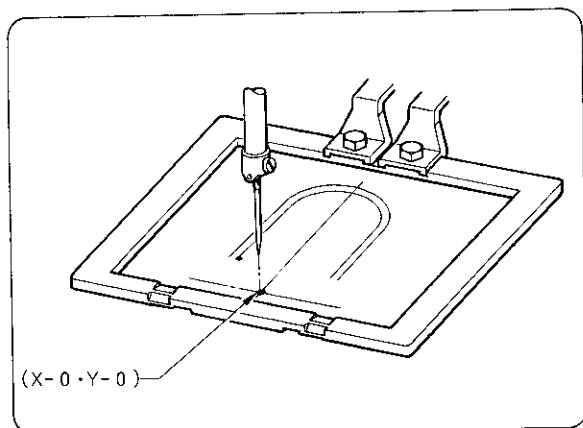

(X-0 · Y-0)

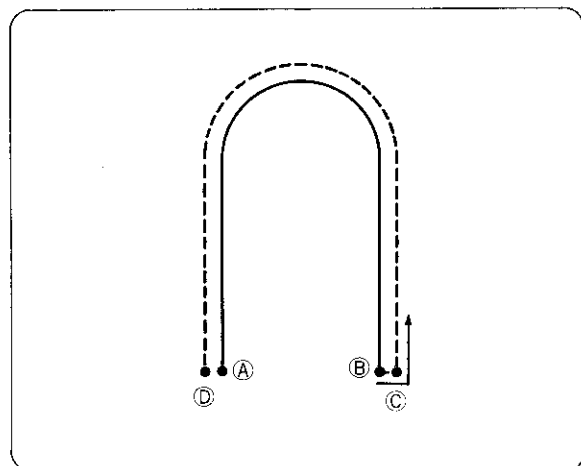
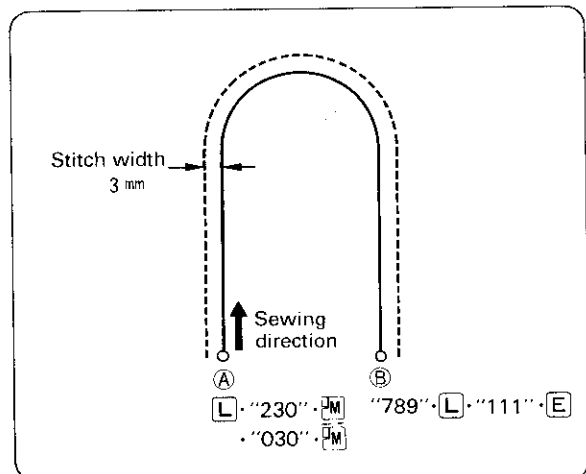

Example: Program the pattern in the figure at left.

- (1) Press the **[P]** key. The work clamp will move to the point of origin (X-0, Y-0), "0" will appear in the STEP display, and command indicator "F" will light.
- (2) Use the direction keys to move the work clamp to the initial stitch position.
- (3) Use the direction keys to position the needle at the sewing start position (A) on the pattern, and then press **[L]** key. The first stitch is now programmed.
- (4) Use the numerical keypad to display "2□□" in the STEP display. The last two digits entered are the stitch width, which can be set from 2 ~ 9.8 mm. If a 3 mm stitch width is desired, the display should read "230".
- (5) Press the **[M]** key.
- (6) Use the numeral keys to enter the stitch length in the STEP display. (e.g., If the stitch length is 3 mm, "030" should be displayed.)
- ※ If the stitch length is not specified, or if a stitch length greater than 8.0 mm ("080" in the STEP display) is entered, it will be automatically be reset to 2 mm.
- (7) Press the **[M]** key. Command indicators "F" and "M" will be on.
- (8) Program to point the (B) using the smoothing function. (See **[5]** Smoothing, page 7.)
- (9) At (B), enter "789" in the STEP display with the keypad, and press the **[L]** key. Then press the **[I]** key three times to display "111", and press the **[E]** key. An electronic alarm will beep, indicating the pattern is being processed. After processing is completed, the needle will move slowly from (B) → (C) → (D). Programming is completed when the needle reaches (D).
- (10) Press the R/W switch to write the pattern to disk. (Refer to page 24.)
- (11) Press the **[P]** key.

Note 1 Be sure to use the smoothing function alone when programming double stitch patterns.

Note 2 If the base pattern contains extremely short corners or fine curves, it may not be possible to obtain the desired double stitch pattern.

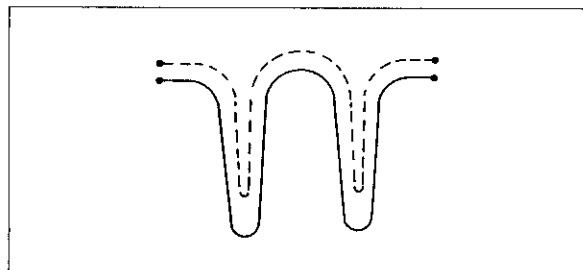

7 To program an intermittent stitch sewing operation

- After the thread trimming operation is completed, if the sewing operation is to be continued without lifting the work clamp, use the **[F]** key (Feed key) to facilitate the programming operation.

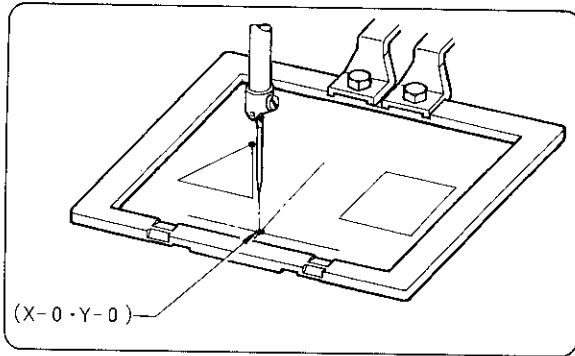

Example: Program the pattern in the figure at left.

- Press the **[P]** key. The work clamp will move to the point of origin (X-0; Y-0), the numeral "0" will be indicated on the STEP display, and the command indicator "F" will illuminate.
- Operate the direction keys to move the work clamp to the initial stitch position.
- When the tip of the needle and the initial stitch position **(A)** on the outline of the needle movement become aligned, press the **[L]** key. Thus, the initial stitch will be programmed.
- Repeat the above procedure to program the remaining stitches of pattern 1.
- Press the **[L]** key at the final stitch position **(B)** of pattern 1, and then press the **[F]** key. At this time, the command indicator "F" will illuminate.

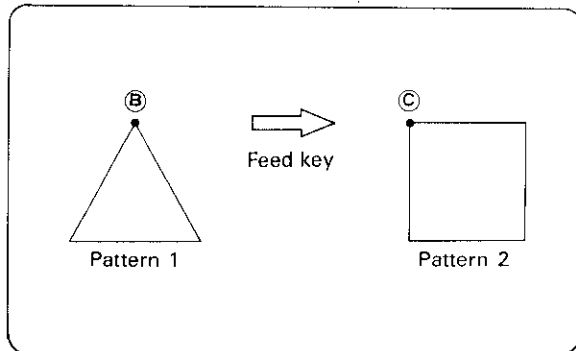
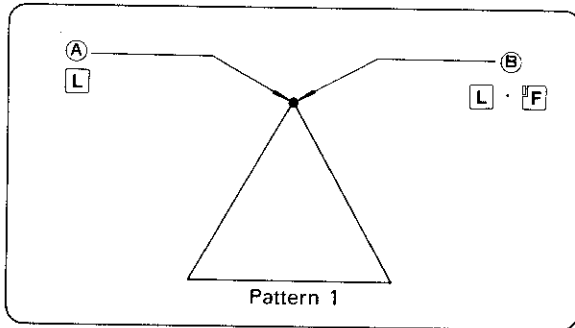

- Operate the direction keys to move the work clamp to the initial stitch position of pattern 2.
- When the tip of the needle and the initial stitch position **(C)** of pattern 2 become aligned, press the **[L]** key. Thus, the operation will be programmed to restart from point **(C)** after the thread trimming operation is completed at point **(B)**.
- Repeat the above procedure to program the remaining stitches of pattern 2.
- Press the **[L]** key at the final stitch position **(D)**, and press the numeral key **[1]** 3 times to indicate "111" on the STEP display. Then, press the **[E]** key.
- The work clamp will move back to the initial stitch position.
- Press the R/W switch to write the pattern to disk. (Refer to page 24.)
- Press the **[P]** key.

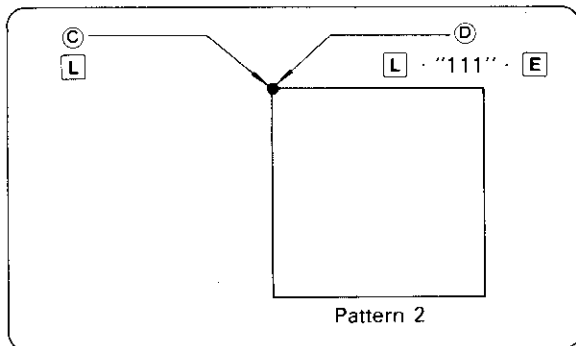

8 To program a basting stitch

- Basting stitches can be easily programmed using the feed stitch mode.

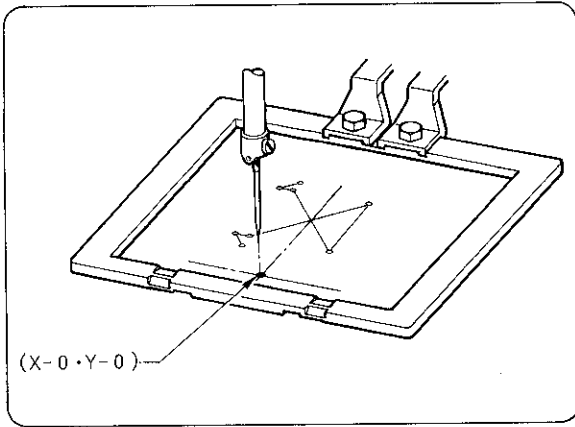

Example: Program the pattern in the figure at left.

- Press the **P** key. The work clamp will move to the point of origin (X-0, Y-0), "0" will appear in the STEP display, and command indicator "F" will light.
- Use the direction keys to move the work clamp to the initial stitch position.
- Use the direction keys to position the needle at the sewing start position **A** on the pattern, and then press the **L** key.
The first stitch is now programmed.
- Use the direction keys and key **L** to program stitch by stitch to **B** and **C**. (Refer to page 5.)
- At **C**, press the **9** key three times to display "999" in the STEP display, and then press the **F** key.

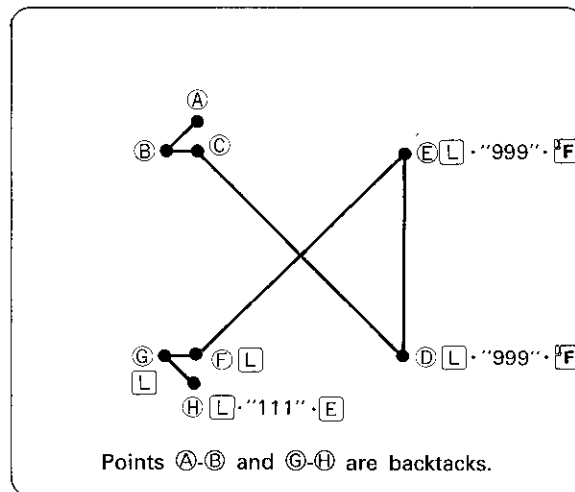
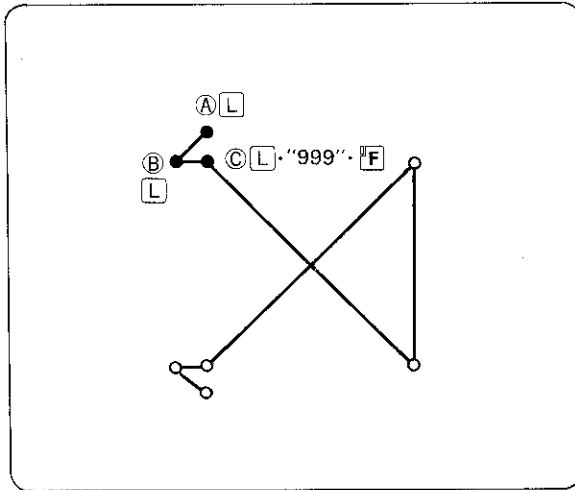

- Use the direction keys to move to point **D**.
- Press the **L** key.
- Program to **F** using the same procedure described in steps (5), (6) and (7).
- Use the direction keys and key **L** to program stitch by stitch to **G** and **H**. (See page 5.)
- After pressing the **L** key at the last stitch **H**, press the **1** key three times to display "111" in the STEP display, and then press the **E** key.
- The work clamp will return to the sewing start position.
- Press the R/W switch to write the pattern to disk. (Refer to page 24.)
- Press the **P** key.

Note With this basting program, you can skip between sewing points without trimming the thread.

9 To program a symmetrical mirror image of a pattern design

A. Use the **M key (Mirror key) to program a symmetrical mirror image of a stitch pattern which has already been programmed.**

Example: Program a symmetrical mirror image of the pattern in the figures below.

- (1) Press the **P** key. The work clamp will move to the point of origin (X-0; Y-0), the numeral "0" will be indicated on the STEP display, and the command indicator "F" will illuminate.
- (2) Insert the disk containing the stitch pattern into the disk drive.
- (3) Press the R/W switch. The data indicator will illuminate and the program data will be read into the memory.
- (4) If the pattern in section ① of the figure on the left is the original design, press "001" to program the pattern in section ②, "011" to program the pattern in section ③, and "010" to program the pattern in section ④. Operate the numeral keys to indicate the appropriate number on the STEP display.
- (5) Press the **M** key, and then press the **L** key.
- (6) Press the R/W switch to write the pattern to disk. (Refer to page 24.)
- (7) Press the **P** key.

Note 1 When the **M** key is used to compose a symmetrical mirror image, the program will be input with the initial stitch position as the starting point of the entire symmetrical pattern as shown in the figures below.

Note 2 In the event that the mirror image may extend beyond the limits of the work clamp, or if the entire symmetrical pattern is to be moved to the center of the work clamp, etc., press the **R** key after completing the procedure from 1~5 mentioned above. Then, press the direction keys to move the work clamp to the newly-established initial stitch position, and press the **L** key. Thus, the newly-established initial stitch position will be programmed.

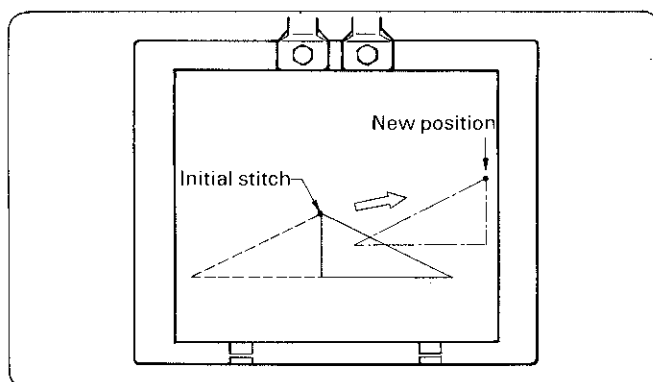
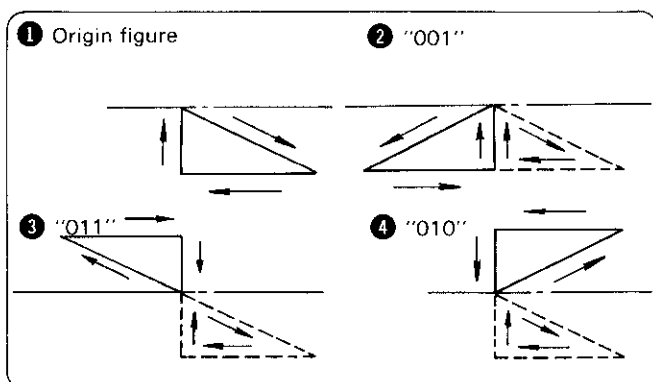
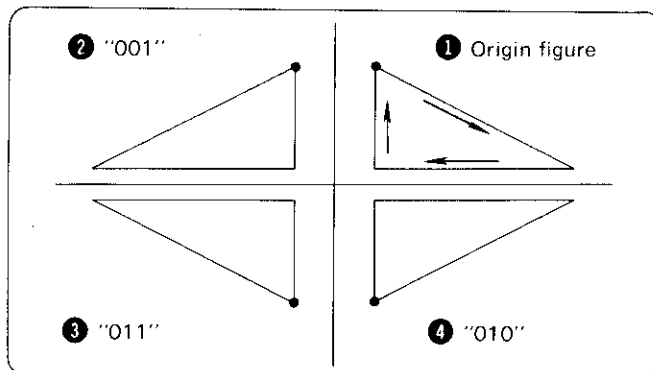
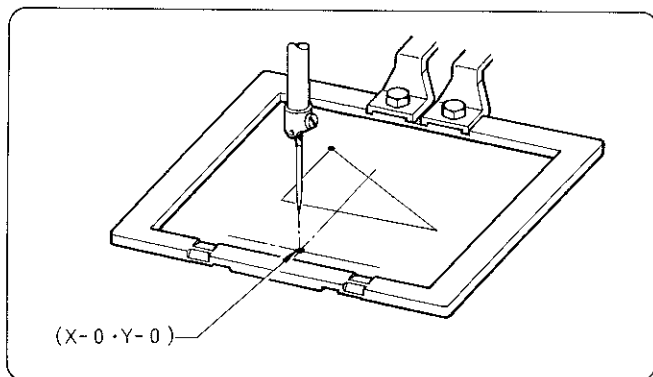

B. To program a symmetrical pattern design, the operator is only required to program one-half of the pattern and use of the numeral keys to program the remaining half of the design.

Example: Program, on the Y axis, a symmetrical mirror of the pattern in the figures below.

- (1) Press the **[P]** key. The work clamp will move to the point of origin (X-0; Y-0), the numeral "0" will be indicated on the display, and the command indicator "F" will illuminate.
- (2) Operate the direction keys to move the work clamp to the initial stitch position.
- (3) When the tip of the needle and the initial stitch position **(A)** on the outline of the needle movement become aligned, press the **[L]** key. Thus, the initial stitch will be programmed.
- (4) Repeat the above procedure to program the left-side half of the stitch pattern from point **(A)** to point **(B)**.
- (5) Press the **[L]** key at point **(B)**. Then, operate the numeral keys to indicate "442" on the STEP display, and press the **[L]** key once again.
- (6) The tip of the needle will slowly move from point **(B)** to point **(A)**, and the right side half of the pattern design will be automatically programmed. At this time, if the presser-lifter pedal is pressed, the work clamp will be fast-forwarded.
- (7) When the tip of the needle becomes aligned with point **(A)**, press the numeral key **[1]** 3 times to indicate "111" on the STEP display. Then, press the **[E]** key.
- (8) The work clamp will move back to the initial stitch position.
- (9) Press the R/W switch to write the pattern to disk. (Refer to page 24.)
- (10) Press the **[P]** key.

※ Repeat Y-axis (442), origin point (440), and X-axis (441) to program pattern (443).

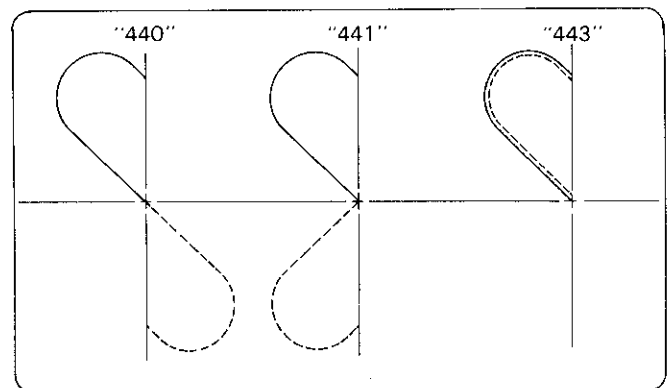
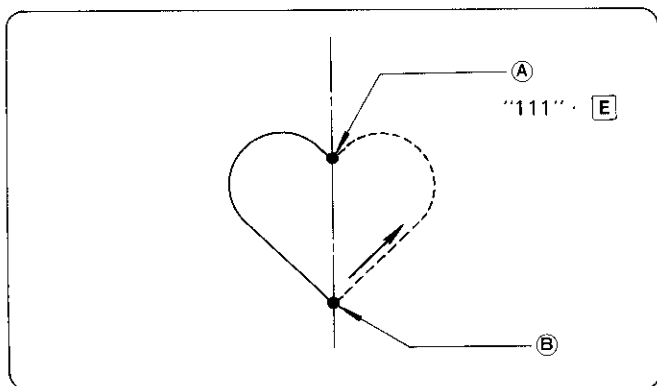
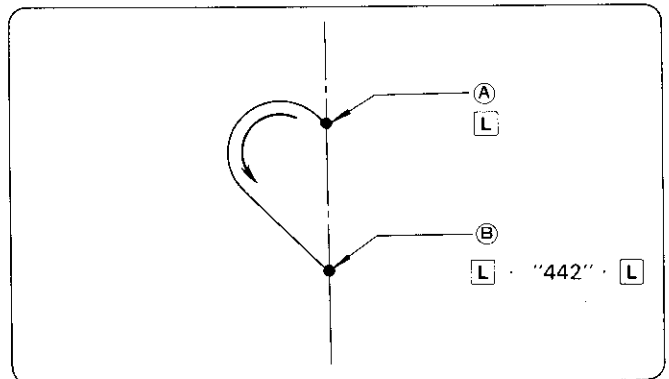
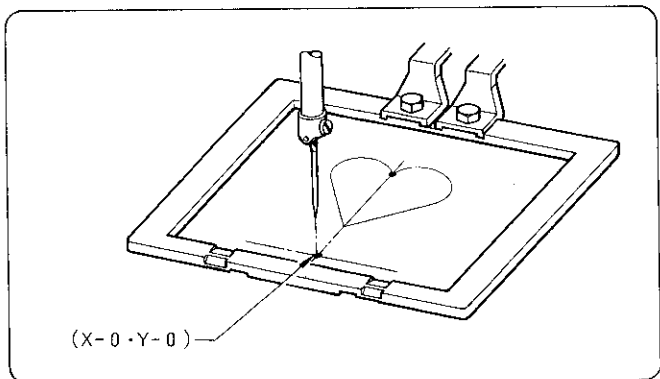

10 To input a split program

- This is a method of programming an independent sewing operation or a sequential sewing operation of a pattern subdivided into smaller portions.

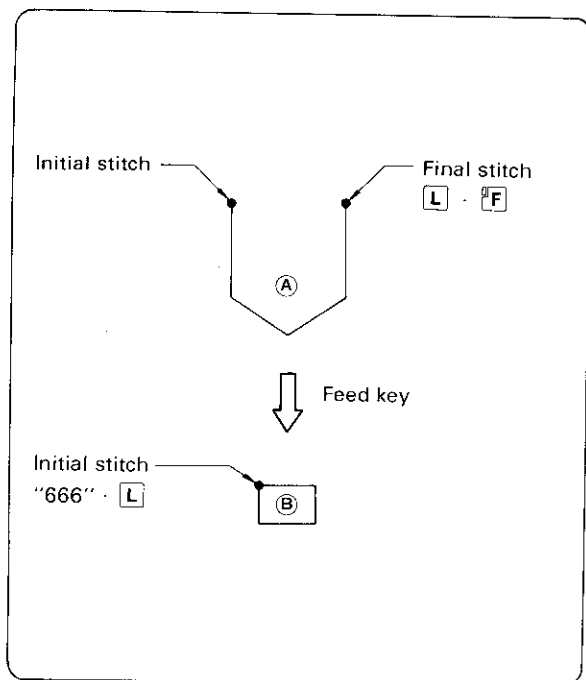

Example: Program the pattern in the figure at left.

- (1) Program pattern (A).
- (2) Press the **L** key at the final stitch position of pattern (A).
- (3) Press the **F** key. The command indicator "F" will illuminate.
- (4) Operate the direction keys to move the work clamp to the initial stitch position of pattern (B).
- (5) Align the tip of the needle with the initial stitch position of pattern (B).
- (6) Press the numeral key **6** 3 times to indicate "666" on the STEP display.
(Note that the feed data "666" on the STEP display refers to a split program input command.)
- (7) Press the **L** key.
- (8) At this time, press the presser-lifter pedal if the pattern on the origin reference plate is to be replaced.

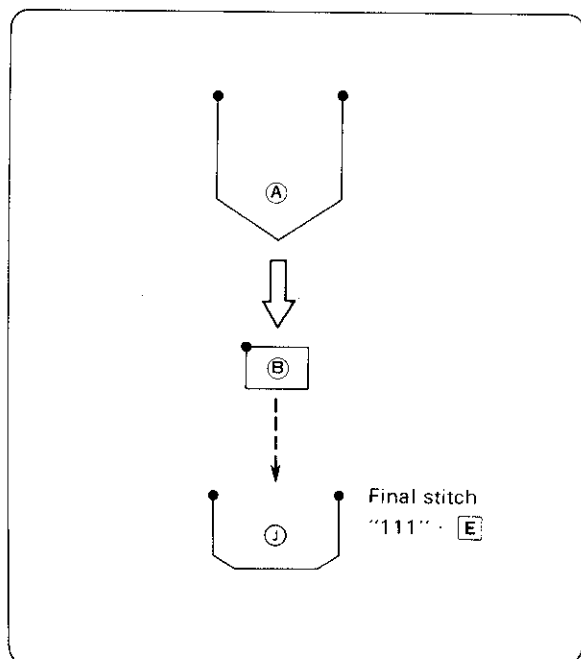

- (9) Up to 10 patterns, i.e., (A), (B) to (J), can be programmed in sequential order.
(A total of up to 2,000 stitches are possible for program (A)~(J).)
- (10) When the programming operation of the final stitch is completed, press the numeral key **1** 3 times to indicate "111" on the STEP display. Then, press the **E** key.
- (11) The work clamp will move back to the initial stitch position of pattern (A).
- (12) Press the R/W switch to write the pattern to disk.
(Refer to page 24.)
- (13) Press the **P** key.

II Split sewing without intermediate thread trimming

- This unit was designed to cut the thread at the division in split sewing. However, continuous sewing of split patterns and garments in which intermediate thread trimming is undesirable is now possible with the new program for full circumference sewing using special work clamps (inner clamps).

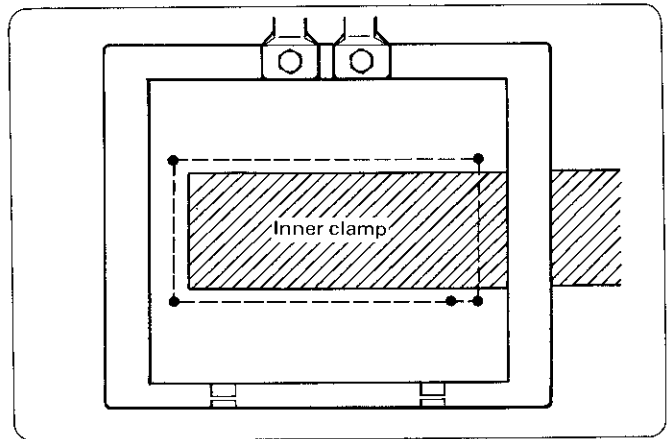
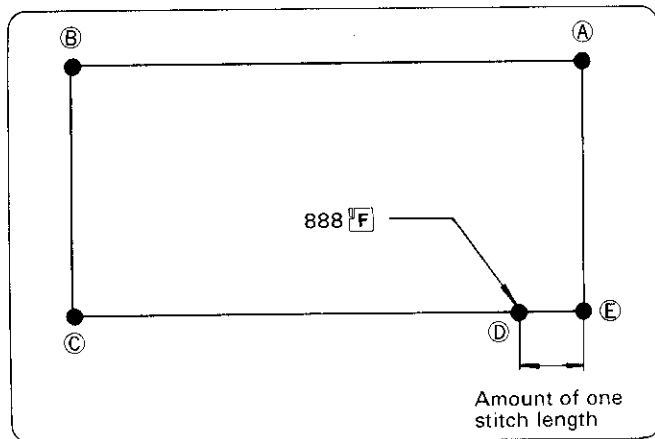

Example: Sewing with a special purpose work clamp (inner clamp).
[programmed method]

- (1) Set the power source switch to the ON position.
- (2) Press the **[F]** key. The work clamp will move to the point of origin (X-0; Y-0), "0" will be indicated in the X, Y, and STEP display and the command indicator "F" will illuminate.
- (3) Use the feed key and program from **(A)** to **(D)**.
- (4) At position **(D)**, use the numeral key **[8]** 3 times to indicate "888" on the STEP display, and then press the **[F]** key.
- (5) Use the feed key and move the needle tip to position **(E)**.
- * The distance from position **(D)** to **(E)** is one stitch length.
- (6) Program from position **(E)** to **(A)**.

(Operation)

- ① Set the work piece as shown in the figure above, and press the starting pedal.
- ② The sewing machine will sew from **(A)** to **(D)**, the thread will be cut at **(E)**, the needle will rise, and the machine will stop.
- ③ Remove the work clamp (inner clamp), and press the starting pedal again.
- ④ The sewing machine will sew from **(E)** to **(A)**.

12 To program a low speed sewing operation in subdivided sections

- If the programming operation is performed according to the regular procedure, the first 1 stitch and the last 2 stitches will be automatically performed at low speed.
- If the sewing speed is to be reduced during the sewing operation (e.g., at acute angles), use the **L** key (Load key) to perform a low speed sewing operation.

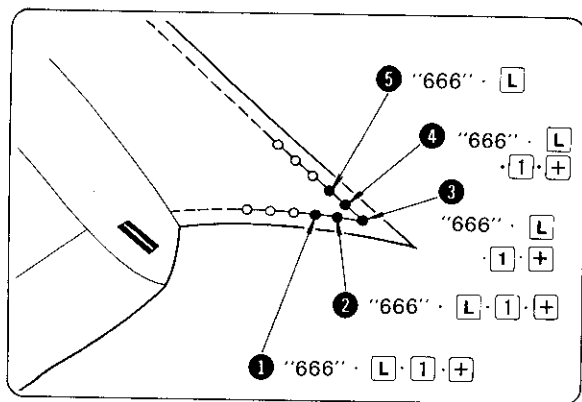

Example: Program a low speed sewing operation from points ① ~ ⑤ on the collar of the garment in the figure at left.

- (1) Press the **P** key. The work clamp will move to the point of origin (X-0; Y-0), the numeral "0" will be indicated on the STEP display, and the command indicator "F" will illuminate.
- (2) Insert the disk containing the proper pattern into the disk drive.
- (3) Press the R/W switch. The data indicator will illuminate, and the program data will be read into the memory.

- (4) Press the numeral key **9** 3 times to indicate "999" on the STEP display, and then press the **+** key. The work clamp will begin to advance one stitch at a time, starting from the initial stitch position.

* Maximum stitch number is 999.

- (5) When the tip of the needle becomes aligned with the position marked ①, press either the **+** key or the **-** key. The work clamp will stop.

(If, however, the work clamp is accidentally advanced beyond the position marked ①, use the numeral keys to indicate on the STEP display the number of stitches to past this position and then press the **-** key. The work clamp will move in the reverse direction as many as indicated on the STEP display.)

- (6) Press the numeral key **6** 3 times to indicate "666" on the STEP display. Then, press the **L** key.
- (7) Press the numeral key **1** to indicate "001" on the STEP display. Then, press the **+** key. The tip of the needle will move to the point marked ②.
- (8) Repeat the procedure (6) and (7) to complete the programming operation from position ② ~ ⑤.

- (9) Press the R/W switch to write the pattern to disk. (Refer to page 24.)

- (10) Press the **P** key.

Note The low speed sewing operation cannot be performed unless the pattern design is complete.

13 To program a stitch pattern by tracing the design.

- A stitch pattern can easily be programmed by operating the numeral keys and the direction keys to trace the pattern design accurately with the tip of the needle.

Example: Program the pattern in the figures below.

- (1) Press the **P** key. The work clamp will move to the point of origin (X-0; Y-0), the numeral "0" will be indicated on the STEP display, and the command indicator "F" will illuminate.
- (2) Operate the direction keys to move the work clamp to the initial stitch position.
- (3) Align the tip of the needle with the initial stitch position **A** on the outline of the needle movement.
- (4) Press the numeral key **5** 3 times to indicate "555" on the STEP display. Then, press the **L** key.
- (5) Operate the numeral keys to indicate the proper stitch length on the STEP display.
(For example, to set the proper stitch length when the actual stitch length is 3 mm, and use the numeral keys to indicate "030" on the STEP display.)
 - ※ If the stitch length is not indicated on the STEP display, or if it exceeds 8.0 mm "080," it will automatically be set to 2 mm.
- (6) Operate the direction keys to accurately trace the pattern with the tip of the needle, starting from the initial stitch position **A**.
- (7) Press the **L** key at the final stitch position **B**.
- (8) Press the numeral key **1** 3 times to indicate "111" on the STEP display. Then, press the **E** key.
- (9) The work clamp will move back to the initial stitch position **A**.
- (10) Press the R/W switch to write the pattern to disk. (Refer to page 24.)
- (11) Press the **P** key.

Note 1 Sections of the pattern, such as sharp corners or especially intricate areas, which require special care when sewing should be programmed with the **L** key.

Note 2 The **F** and **L** keys can be used during programming. Press the **L** key at the beginning and end of areas designated for skip stitching or straight line sewing.

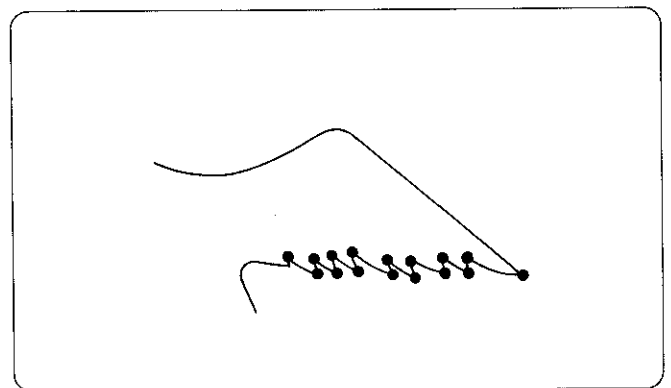
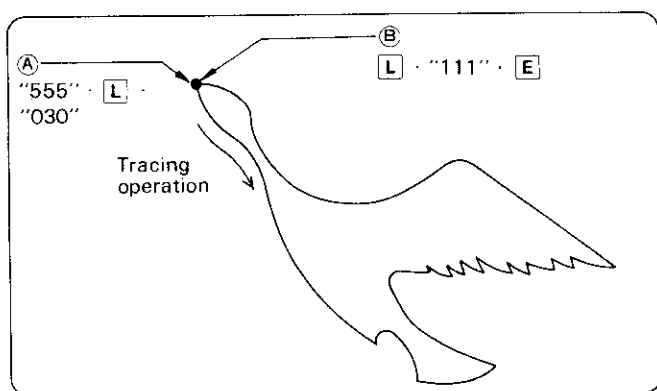
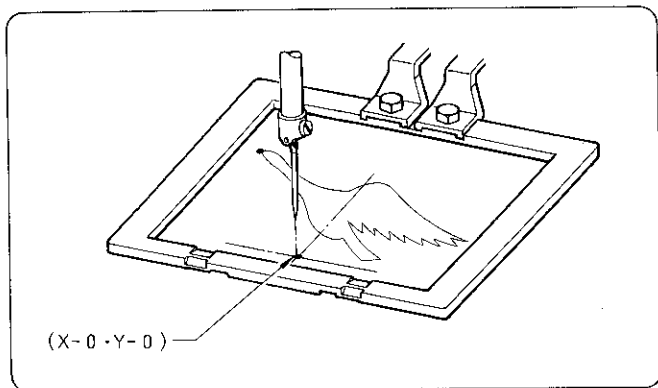

14 To program a design with recurring patterns

- A pattern which has been programmed can easily be repeated by operating the numeral keys.

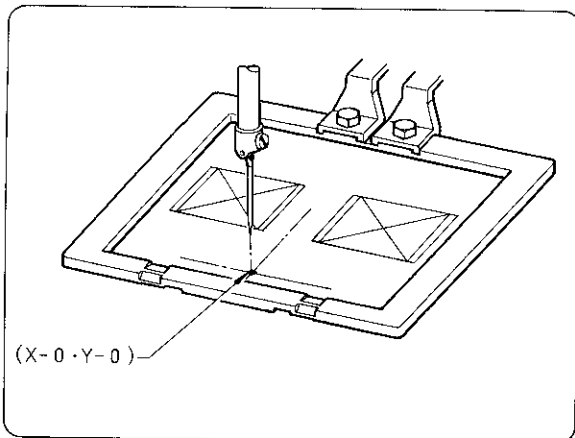

Example: Program the pattern in the figure at left.

- (1) Press the **P** key. The work clamp will move to the point of origin (X-0; Y-0), the numeral "0" will be indicated on the STEP display, and the command indicator "F" will illuminate.
- (2) Operate the direction keys to move the work clamp to the initial stitch position.
- (3) When the tip of the needle and the initial stitch position **A** on the outline of the needle movement become aligned, press the **L** key. Thus, the initial stitch will be programmed.
- (4) Repeat the above procedure to program the remaining stitches of the pattern.
- (5) Press the **L** key at the final stitch position **B**, and then press the **F** key. The command indicator "F" will illuminate.
- (6) Operate the direction keys to move the work clamp to the proper sewing position.
- (7) Align the tip of the needle with the position at which the sewing operation **C** is to be performed. Then, press the **L** key.
- (8) Press the numeral key **3** 3 times to indicate "333" on the STEP display. Then, press the **L** key once again.
- (9) The tip of the needle will slowly trace the recurring pattern, and the programming operation will be automatically performed. At this time, if the presser-lifter pedal is pressed, the work clamp will be fast-forwarded.
- (10) Press the **L** key at the final stitch position **D** of the recurring pattern.
- (11) Press the numeral key **1** 3 times to indicate "111" on the STEP display. Then, press the **E** key.
- (12) The work clamp will move back to the initial stitch position **A** of the original pattern.
- (13) Press the R/W switch to write the pattern to disk. (Refer to page 24.)
- (14) Press the **P** key.

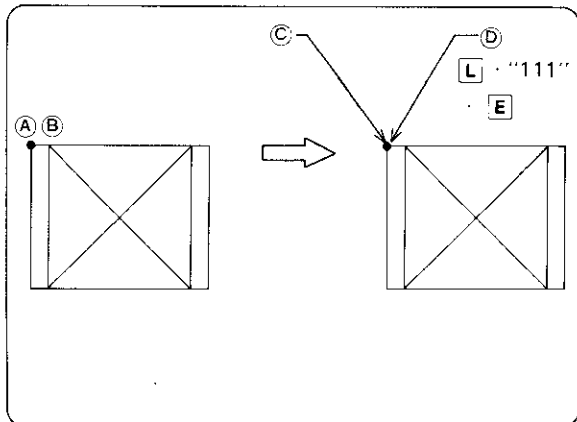
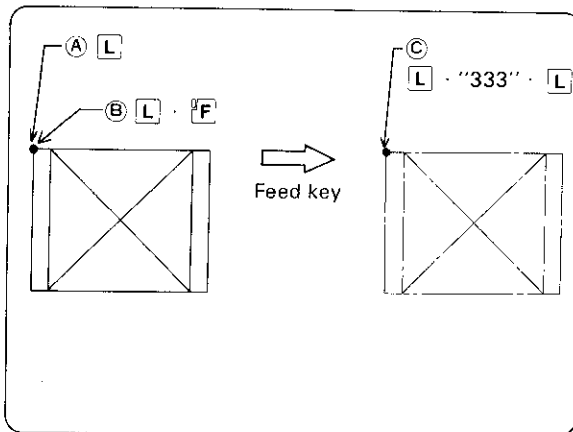

15 To program a zigzag sewing operation

- A zigzag sewing operation can be easily programmed by employing the tracing method.

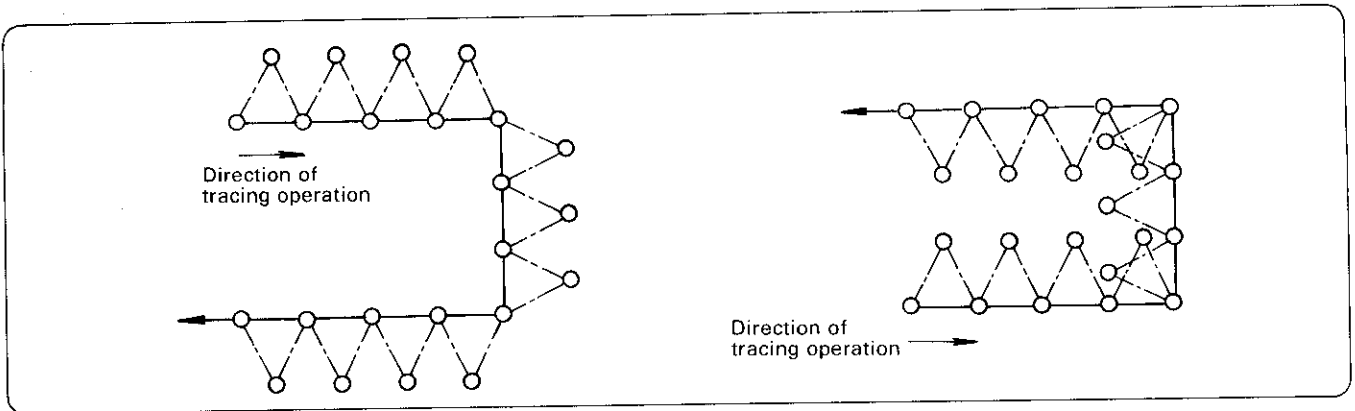

In the zigzag sewing operation, patterns will appear only to the left side on the direction of the tracing operation as shown in the figure above.

Therefore, it is necessary to establish the proper direction of the tracing operation according to the requirements of the sewing material.

A. To program a zigzag operation.

Example: Program the pattern in the figures below.

- (1) Press the **P** key. The work clamp will move to the point of origin (X-0; Y-0), the numeral "0" will be indicated on the STEP display, and the command indicator "F" will illuminate.
- (2) Operate the direction keys to move the work clamp to the initial stitch position.
- (3) Align the tip of the needle with the initial stitch position (A) on the outline of the needle movement.
- (4) Operate the numeral keys to indicate "77 " on the STEP display. The last digit is the numeral obtained by dividing the stitch width (λ) by the pitch (P) - 1.
Therefore, $(\lambda) \div (P) - 1$. In this instance, $3 \text{ mm} \div 3 \text{ mm} - 1 = 0$.
Therefore, indicate "770" on the STEP display.

Note Set the zigzag width and stitch length so that areas corresponding to () number 0 to 9 are positive numbers.

- (5) Press the **L** key.
- (6) Establish the proper pitch.
Therefore, indicate "030" on the STEP display.
- (7) Operate the direction keys so that the tip of the needle accurately traces the operation design, starting from the initial stitch position (A).
- (8) Press the **L** key at the final stitch position.
- (9) Press the numeral key **1** 3 times to indicate "111" on the STEP display. Then, press the **E** key.
- (10) The presser will move back to the initial stitch position.
- (11) Press the R/W switch to write the pattern to disk. (Refer to page 24.)
- (12) Press the **P** key.

Note The **L** key is to be pressed, only at procedure 5 mentioned above.
Otherwise, do not press the **L** key or the **R** key.

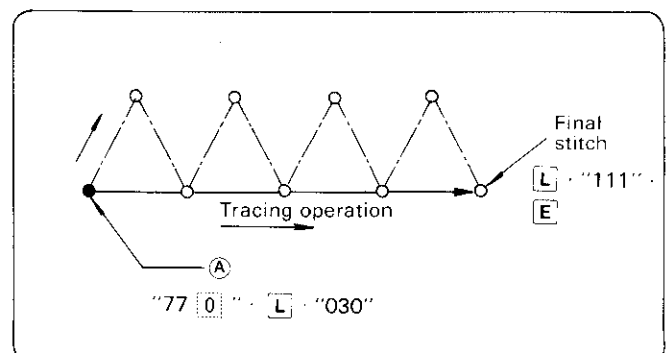
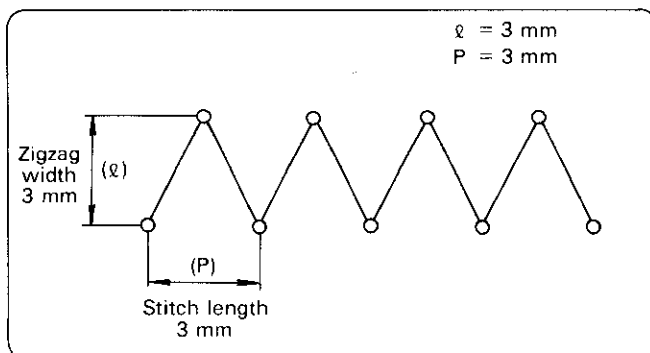

B. To program an intermittent stitch sewing operation (feed) during the zigzag sewing operation.

1. If the zigzag sewing pattern preceding or following the intermittent stitch sewing operation remains unchanged.

Example: Program the pattern in the figures below.

- (1) Press the **[P]** key. The work clamp will move to the point of origin (X-0; Y-0), the numeral "0" will be indicated on the STEP display, and the command indicator "F" will illuminate.
- (2) Operate the direction keys to move the work clamp to the initial stitch position.
- (3) Align the tip of the needle with the initial stitch position **(A)** on the outline of the needle movement.
- (4) Operate the numeral keys to indicate "77□" on the STEP display. The last digit □ is the numeral obtained by dividing the stitch width (ℓ) by the pitch (P) - 1.
Therefore, $(\ell) \div (P) - 1$. In this instance, $4 \text{ mm} \div 2 \text{ mm} - 1 = 1$.
Therefore, indicate "771" on the STEP display.
- (5) Press the **[L]** key.
- (6) Establish the proper pitch.
Therefore, indicate "020" on the STEP display.
- (7) Operate the direction keys so that the tip of the needle accurately traces the pattern design, starting from the initial stitch position **(A)**, and trace to position **(B)**.
- (8) Press the **[F]** key. The command indicator "F" will illuminate.
- (9) Operate the direction keys to move the work clamp to the initial stitch position of the next sewing operation.
- (10) Press the **[L]** key when the tip of the needle becomes aligned with the initial stitch position **(C)**.
- (11) Operate the direction keys so that the tip of the needle accurately performs the tracing operation from point **(C)** → **(D)** in the pattern design.
- (12) Press the **[L]** key at the final stitch position **(D)**.
- (13) Press the numeral key **[1]** 3 times to indicate "111" on the STEP display. Then, press the **[E]** key.
- (14) The work clamp will move back to the initial stitch position.
- (15) Press the R/W switch to write the pattern to disk. (Refer to page 24.)
- (16) Press the **[P]** key.

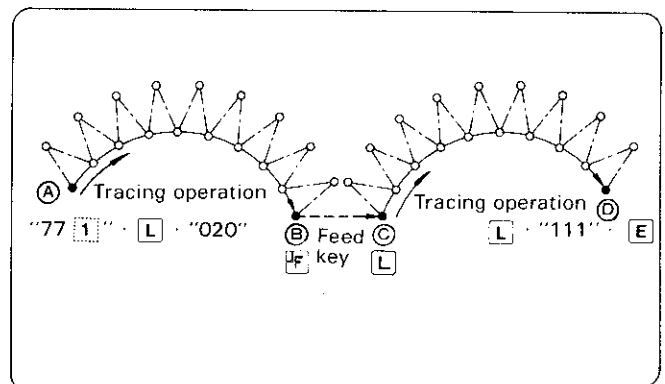
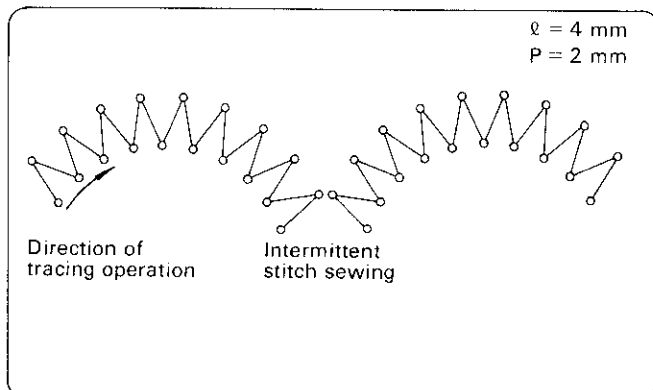

2. If the zigzag sewing pattern preceding or following the intermittent stitch sewing operation is changed.

Example: Program the pattern in the figures below.

- (1) Press the **P** key. The work clamp will move to the point of origin (X-0; Y-0), the numeral "0" will be indicated on the STEP display, and the command indicator "F" will illuminate.
- (2) Operate the direction keys to move the work clamp to the initial stitch position.
- (3) Align the tip of the needle with the initial stitch position **A** on the outline of the needle movement.
- (4) Operate the numeral keys to indicate "77□" on the STEP display. The last digit □ is the numeral obtained by dividing the stitch width (ℓ) by the pitch (P) - 1.
Therefore, $(\ell) \div (P) - 1$. In this instance, $4 \text{ mm} \div 2 \text{ mm} - 1 = 1$.
Therefore, indicate "771" on the STEP display.
- (5) Press the **L** key.
- (6) Establish the proper pitch.
Therefore, indicate "020" on the STEP display.
- (7) Operate the direction keys so that the tip of the needle accurately traces the pattern design, starting from the initial stitch position **A**, and trace to position **B**.
- (8) Press the **R** key. The work clamp will move back to the point of origin.
- (9) Operate the direction keys to move the work clamp to the initial stitch position.
- (10) Align the tip of the needle with the initial stitch position **A** on the outline of the needle movement.
- (11) Follow procedure (4) mentioned above to indicate "77 □" on the STEP display.
In this instance, $3 \text{ mm} \div 3 \text{ mm} - 1 = 0$.
Therefore, indicate "770" on the STEP display.
- (12) Press the **L** key.
- (13) Press the numeral key **9** 3 times to indicate "999" on the STEP display, and then press the **+** key. The work clamp will move one stitch at a time from the initial stitch position.
- (14) The tip of the needle becomes aligned with position **B**.
- (15) Press the **F** key. The command indicator "F" will illuminate.
- (16) Operate the direction keys to move the work clamp to the initial stitch position of the next sewing operation.
- (17) Press the **L** key when the tip of the needle becomes aligned with the initial stitch position **C**.
- (18) Indicate the proper pitch on the STEP display according to procedure (6) mentioned above.
* Display "030" in the STEP indicator.
- (19) Operate the direction keys so that the tip of the needle accurately performs the tracing operation from point **C** → **D** in the pattern design.
- (20) Press the **L** key at the final stitch position **D**.
- (21) Press the numeral key **1** 3 times to indicate "111" on the STEP display. Then, press the **E** key.
- (22) The work clamp will move back to the initial stitch position.
- (23) Press the R/W switch to write the pattern to disk. (Refer to page 24.)
- (24) Press the **P** key.

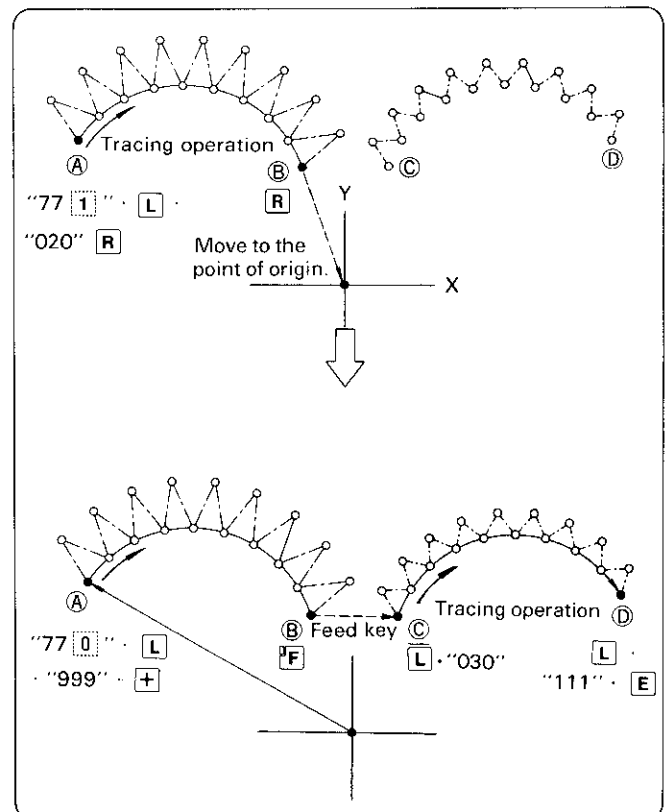
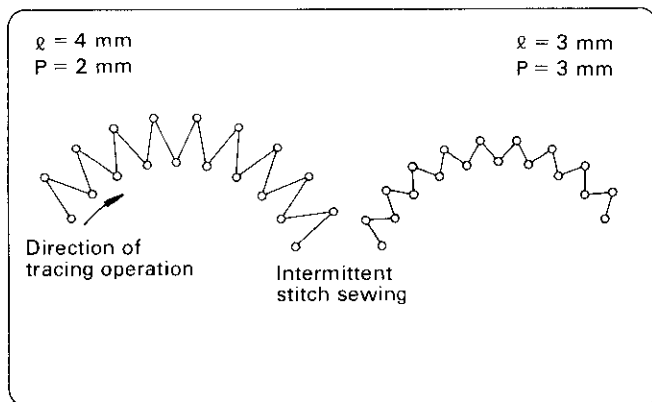

C. To program a regular sewing operation during a zigzag sewing operation.

Example: Program the pattern in the figures below.

- (1) Press the **[P]** key. The work clamp will move to the point of origin (X-0; Y-0), the numeral "0" will be indicated on the STEP display, and the command indicator "F" will illuminate.
- (2) Operate the direction keys to move the work clamp to the initial stitch position **(A)** on the outline of the needle movement.
- (3) Align the tip of the needle with the initial stitch position **(A)** on the outline of the needle movement.
- (4) Operate the numeral keys to indicate "77" on the STEP display. The last digit is the numeral obtained by dividing the stitch width (ℓ) by the pitch (P) - 1.
Therefore, $(\ell) \div (P) - 1$. In this instance, $4 \text{ mm} \div 2 \text{ mm} - 1 = 1$.
Therefore, indicate "771" on the STEP display.
- (5) Press the **[L]** key.
- (6) Establish the proper pitch.
Therefore, indicate "020" on the STEP display.
- (7) Operate the direction keys so that the tip of the needle accurately traces the pattern design, starting from the initial stitch position **(A)**, and trace to position **(B)**.
- (8) Press the **[F]** key. The command indicator "F" will illuminate.
- (9) Operate the direction keys to move the work clamp to the initial stitch position of next sewing operation.
- (10) Press the **[L]** key when the tip of the needle becomes aligned with the initial stitch position **(C)**.
- (11) Operate the direction keys so that the tip of the needle accurately traces from point **(C)** → **(D)** in the pattern design.
- (12) Press the **[L]** key at the final stitch position **(D)**.
- (13) Press the numeral key **[1]** 3 times to indicate "111" on the STEP display. Then, press the **[E]** key.
- (14) The work clamp will move back to the initial stitch position.
- (15) Press the **[R]** key. The work clamp will move back to the point of origin.
- (16) Press the numeral key **[9]** 3 times to indicate "999" on the STEP display, and then press the **[+]** key. The work clamp will move one stitch at a time from the initial stitch position.
- (17) When the tip of the needle becomes aligned with position **(B)**, press either the **[+]** or the **[-]** key. The work clamp movement will stop. (If, however, the work clamp is accidentally moved beyond point 4, indicate on the STEP display the number of stitches past point 4, and then press the **[-]** key. The work clamp will move as many times as indicated on the STEP display in the reverse direction.)
- (18) Program the stitches from point **(B)** to point **(C)**.
- (19) Press the **[L]** key at point **(C)**.
- (20) Press the **[C]**, **[1]**, and **[+]** keys in that order.
- (21) Press the R/W switch to write the pattern to disk. (Refer to page 24.)
- (22) Press the **[P]** key.

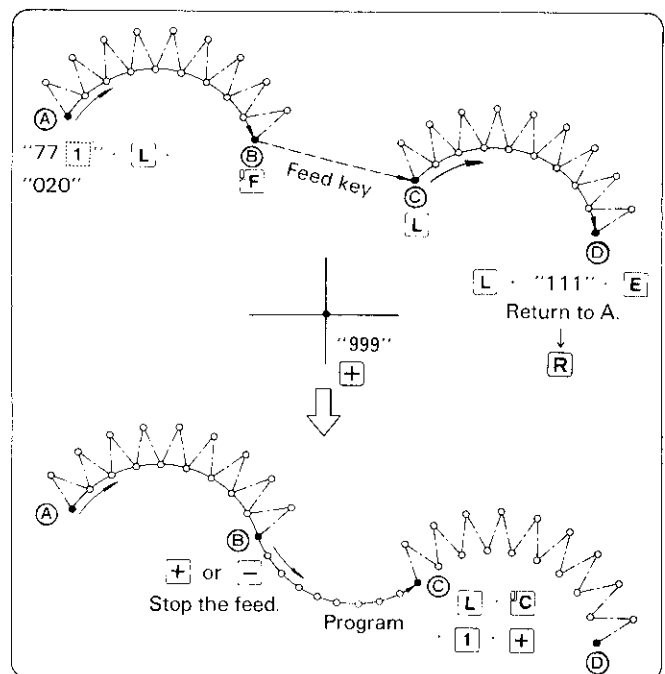
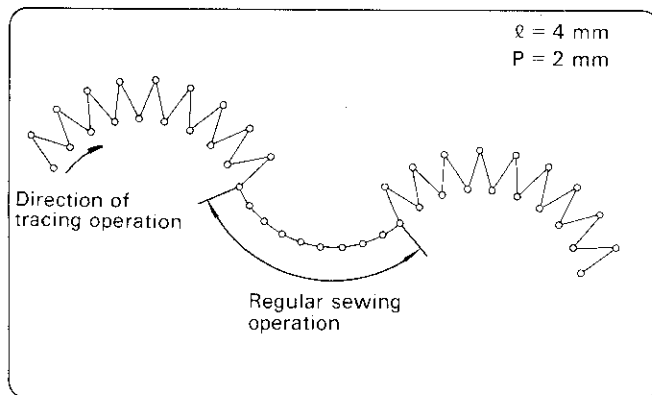

16 To program enlargement/reduction patterns

- Any previously programmed pattern can be enlarged or reduced.

Example: Program the pattern in the figures below.

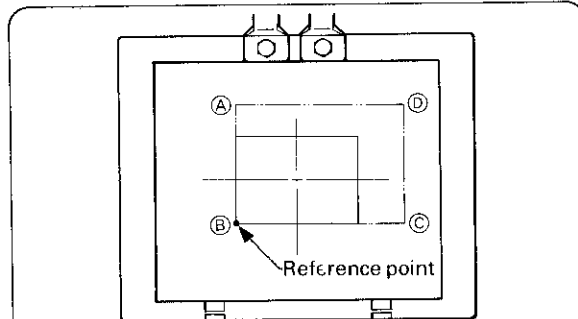
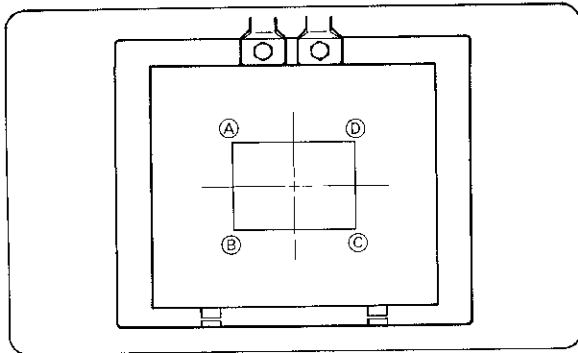

If the reference point is changed.

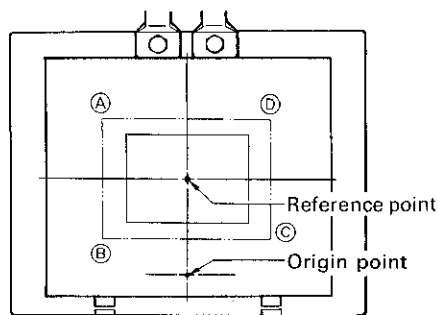

If the reference point is not changed

- Turn the power on.
- Press the **[P]** key. The work clamp will move to the point of origin (X-0, Y-0), "0" will appear in the STEP display, and command indicator "F" will light.
- Insert the disk and read the desired pattern (previously programmed) from disk.
- Use the direction keys to position the needle at enlargement/reduction reference point **(B)** (any desired point). If the needle is not moved, the center of the position of the work clamp (X-0, Y-0) becomes the enlargement/reduction reference point.
- Press the **[8]** key three times to display "888" in the STEP display, and then press the **[M]** key. The X-Y indicators will go out, and the STEP display will read "000". The enlargement/reduction mode is now set.
- Use the numerical keypad to enter the X-axis ratio in the STEP display, "150" in this example. The enlargement/reduction ratio can be set from "000" ~ "199" (i.e., 0% to 199%). Press the **[M]** key, and the upper two digits "15" will be displayed in the "X" indicator. If a different ratio is to be used for the X-axis, enter this ratio.
* Any ratio over 199% will be invalid.
- Use the numerical keypad to enter the Y-axis ratio in the STEP display, "150" in this example. The enlargement/reduction ratio can be set from "000" ~ "199" (i.e., 0% to 199%). Press the **[M]** key, and the upper two digits "15" will be displayed in the "Y" indicator. If a different ratio is to be used for the Y-axis, enter this ratio.
* Any ratio over 199% will be invalid.
- Use the numeral keys to enter the stitch length in the STEP display. (e.g., If the stitch length is 3 mm. "030" should be displayed.) If the stitch length is not specified (the STEP display remains "000"), the same number of stitches used in the original pattern will be used to sew the enlargement or reduction version.

- Press the **[L]** key. If the stitch length was specified, an electronic alarm will beep, indicating the pattern is being processed. If the same number of stitches is used, the STEP display will decrement one step at a time, indicating processing of the program.
- Select a different program number, and press the data switch to write the pattern to disk. (Refer to page 24.)
- Press the **[P]** key.

Note 1 Enlargement/reduction patterns are enlarged or reduced using the point at which "888" **[M]** key was pressed as the reference point.

If the needle is at the origin, the center of the work clamp will be the reference point.

Note 2 If the stitch length of an enlarged pattern exceeds 8.0 mm, or if the sewing area exceeds X = 100 mm and Y = 60 mm, all indicators will go out, and enlargement/reduction will be terminated. If this happens, use a different ratio and repeat from step 2.

17 If a command key is pressed accidentally

- Data contents will not be modified if one of the command keys (**[F]** **[M]** **[C]** **[L]**) is pressed accidentally. To cancel the command key selection, simply press **[+]** or **[-]**.

HOW TO WRITE DATA TO DISK

1 To write program data to disk

- Follow the procedure below to write program data to disk.

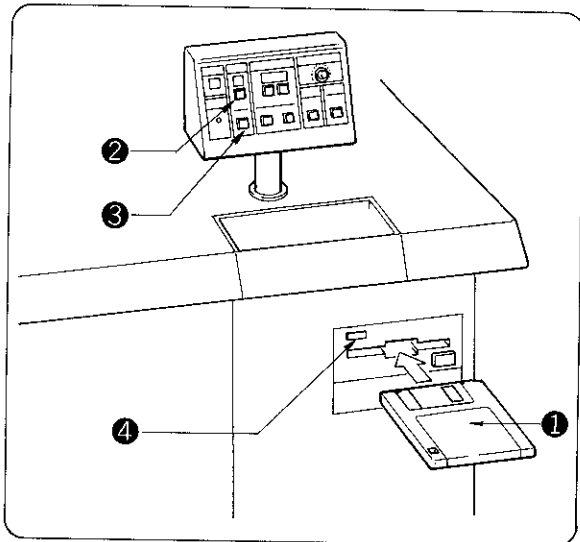

- (1) Insert disk ① with the label up all the way into the drive.
- (2) Press the program number switch ② to display a program number at which no data is recorded.
- (3) Press the R/W (Read/Write) switch ③.
- (4) The drive indicator ④ will light while data is being written to disk.

When the indicator ④ goes out, an alarm will sound to indicate the program was successfully written.

- ※ Press the **P** key to enter the sewing mode.

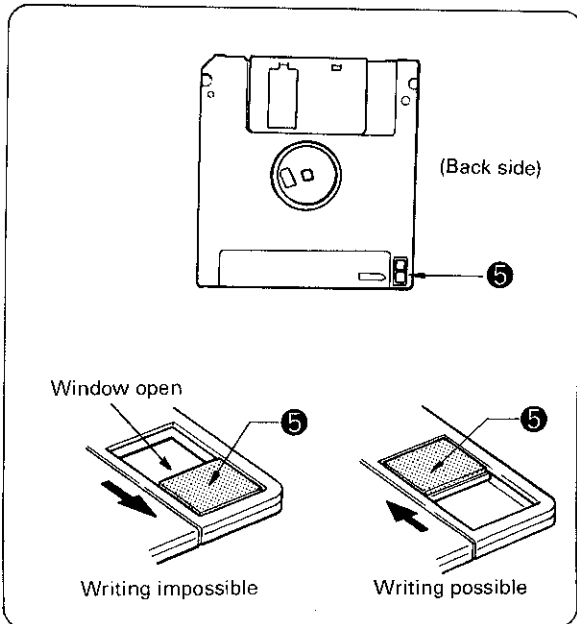

- ※ Slide the write protect tab ⑤ down after writing data to disk.

Data cannot be written to or erased from disk when the write protect window is open. To rewrite data to disk, close the write protect tab ⑤ over the window.

HOW TO REVISE THE PROGRAM

- Use the **[C]** key to revise a program according to alterations made in the pattern design or to correct a program which was input incorrectly.

1 To revise a section of a stitch pattern program from points according to alterations made in the stitch pattern design

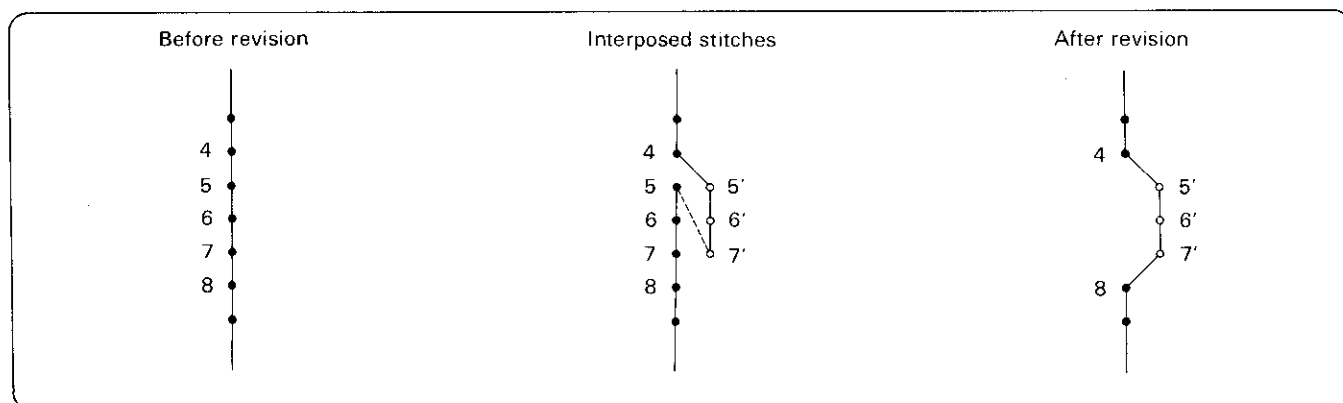

- (1) Set the power source switch to the ON position.
- (2) Press the **[P]** key. The work clamp will move to the point of origin (X-0; Y-0), the numeral "0" will be indicated on the STEP display, and the command indicator "F" will illuminate.
- (3) Insert the disk containing the stitch pattern program to perform the read operation.
- (4) Press the numeral key **[9]** 3 times to indicate "999" on the STEP display, and then, press the **[+]** key. The work clamp will move one stitch at a time from the initial stitch position.
 - ※ Maximum stitch number is 999.
- (5) When the tip of the needle becomes aligned with point 4, press either the **[+]** or the **[-]** key. The work clamp movement will stop. (If, however, the work clamp is accidentally moved beyond point 4, indicate on the STEP display the number of stitches past point 4, and then press the **[-]** key. The presser clamp will move as many times as indicated on the STEP display in the reverse direction.)
- (6) Operate the direction keys to align the tip of the needle with point 5', and then press the **[L]** key. Thus, point 5' will be programmed.
- (7) Follow the above procedure to program points 6' and 7'.
- (8) Operate the numeral keys to indicate "001" on the STEP display, and then press the **[+]** key. The tip of the needle will move to point 5. Thus, points 5', 6' and 7' will be interposed between points 4 and 5.
- (9) Press the **[C]** key. The command indicator "C" will illuminate.
- (10) Operate the numeral keys to indicate on the STEP display the number of stitches to be cancelled. (In this instance, indicate "003" on the STEP display to cancel points 5, 6 and 7.)
- (11) Press the **[+]** key. The tip of the needle will move to points 6, 7 and 8. Thus, the 3 points 5, 6 and 7 will be cancelled and the program will be revised so that the needle will move from point 4 → 5' → 6' → 7' → 8.
- (12) Press the R/W switch to write the pattern to disk. (Refer to page 24.)
- (13) Press the **[P]** key to enter the sewing mode.

2 To cancel the initial stitch of a stitch pattern which has already been programmed.

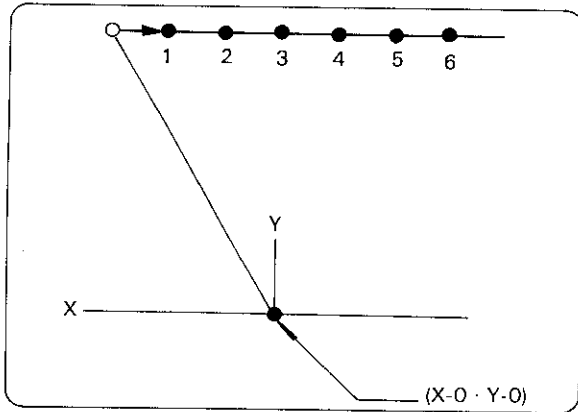

- (1) Set the power source switch to the ON position.
- (2) Press the **[P]** key. The work clamp will move to the point of origin (X-0; Y-0), the numeral "0" will be indicated on the STEP display, and the command indicator "F" will illuminate.
- (3) Insert the disk containing the stitch pattern program to perform the read operation.
- (4) Press the numeral key **[1]** and the **[+]** key. The tip of the needle will move to the initial stitch position of the program.
- (5) Press the **[C]** key, the numeral key **[1]**, and the **[+]** key in that order. The initial stitch will be cancelled, and the tip of the needle will move to the second stitch position.

- (6) Press the R/W switch to write the pattern to disk. (Refer to page 24.)
- (7) Press the **[P]** key to enter the sewing mode.

3 To cancel the initial stitch of a pattern and reprogram the newly-established initial stitch position

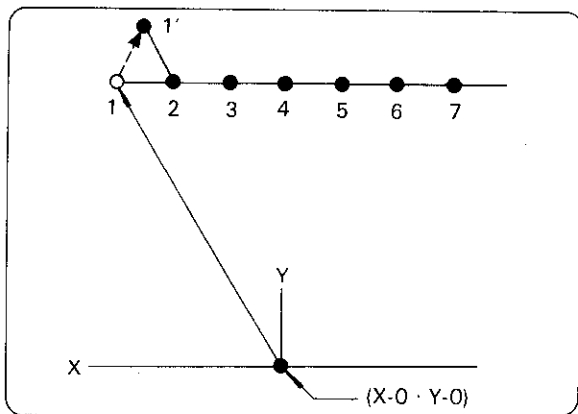

- (1) Set the power source switch to the ON position.
- (2) Press the **[P]** key. The work clamp will move to the point of origin (X-0; Y-0), the numeral "0" will be indicated on the STEP display, and the command indicator "F" will illuminate.
- (3) Insert the disk containing the stitch pattern program to perform the read operation.
- (4) Press the numeral key **[1]** and the **[+]** key. The tip of the needle will move to the initial stitch position.
- (5) Operate the direction keys to move the tip of the needle from the initial stitch position 1 to the newly-established initial stitch position 1'. Then, press the **[L]** key.

Note If the distance between the initial stitch position 1 and the newly-established initial stitch position 1' is greater than 8.0 mm, press either the **[F]** key, and then operate the direction keys to move the tip of the needle to the newly-established initial stitch position 1'. Then, press the **[L]** key.

- (6) Press the numeral key **[1]** and the **[−]** key. The tip of the needle will move to the original initial stitch
- (7) Press the **[C]**, **[1]** and **[+]** keys in that order. The original initial stitch position 1 will be cancelled, and the tip of the needle will move to the second stitch position 2.
- (8) Press the R/W switch to write the pattern to disk. (Refer to page 24.)
- (9) Press the **[P]** key to enter the sewing mode.

4 To program a sewing operation prior to the initial stitch position of the pattern which has already been programmed.

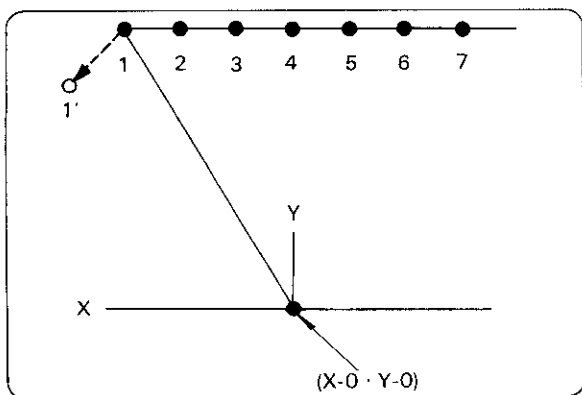

- (1) Set the power source switch to the ON position.
- (2) Press the **[P]** key. The work clamp will move to the point of origin (X-0; Y-0), the numeral "0" will be indicated on the STEP display, and the command indicator "F" will illuminate.
- (3) Insert the disk containing the stitch pattern program to perform the read operation.
- (4) Press the numeral key **[1]** and the **[+]** key. The tip of the needle will move to the initial stitch position.
- (5) Press either the **[F]** key, and then operate the direction keys to move the tip of the needle to the initial stitch position. Then, write down the coordinates (the X and Y values) on a piece of paper, and press the **[L]** key.

- (6) Input the feed key and **[L]** or **[Li]** key between the first and last stitches, and program all sewing points to the preprogrammed coordinate (X and Y coordinates).

Note Establish the number of additional sewing positions according to the distance and the stitch pitch between the newly-established stitch position 1' and the initial stitch position 1.

- (7) Press the **[R]** key. The work clamp will move back to the point of origin.
- (8) Press the numeral key **[1]** and the **[+]** key. The tip of the needle will move to the initial stitch position.
- (9) Press the **[C]** key, the numeral key **[1]**, and the **[+]** key in that order. The tip of the needle will move to the newly-established stitch position 1', and thus a stitch position prior to the initial stitch position 1 will be programmed.
- (10) Press the R/W switch to write the pattern to disk. (Refer to page 24.)
- (11) Press the **[P]** key to enter the sewing mode.

5 To program a shunting point prior to the initial stitch position of the pattern which has already been programmed.

※ In the event that work clamp would come into contact with the needle or the presser foot if it were lifted at the initial stitch position, a shunting point is used as an alternative point where the work clamp is to be lifted.

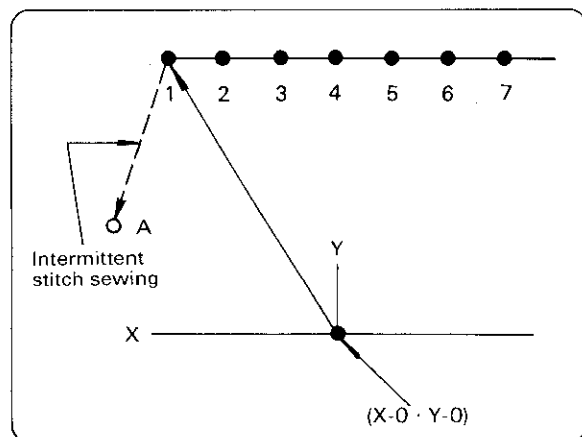

- (1) Set the power source switch to the ON position.
- (2) Press the **[P]** key. The work clamp will move to the point of origin (X-0; Y-0), the numeral "0" will be indicated on the STEP display, and the command indicator "F" will illuminate.
- (3) Insert the disk containing the stitch pattern program to perform the read operation.
- (4) Press the numeral key **[1]** and the **[+]** key. The tip of the needle will move to the initial stitch position of the program.
- (5) Press the **[F]** key, and then operate the direction keys to move the tip of the needle to point A (the shunting point.) Then, write down the coordinates (the X and Y values) on a piece of paper, and press the **[L]** key.

- (6) Input the feed key and the **[L]** or **[Li]** key between the first and last stitches, and program all sewing points to the preprogrammed coordinate (X and Y coordinates).
- (7) Press the numeral key **[2]** and the **[−]** key. The tip of the needle will move from the initial stitch position to point A and then back to the initial stitch position.
- (8) Press the **[C]** key, the numeral key **[1]**, and the **[+]** key in that order. The tip of the needle will move to point A, and thus the shunting point will be added onto the program prior to the initial stitch position.
- (9) Press the R/W switch to write the pattern to disk. (Refer to page 24.)
- (10) Press the **[P]** key to enter the sewing mode.

6 To shift the shunting point from point A to point B

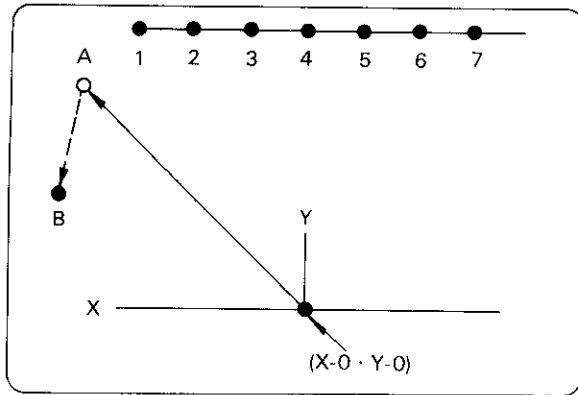

- (1) Set the power source switch to the ON position.
- (2) Press the **[P]** key. The work clamp will move to the point of origin (X-0; Y-0), the numeral "0" will be indicated on the STEP display, and the command indicator "F" will illuminate.
- (3) Insert the disk containing the stitch pattern program to perform the read operation.
- (4) Press the numeral key **[1]** and the **[+]** key. The tip of the needle will move to the shunting point A.
- (5) Press the **[F]** key, and then operate the direction keys to move the tip of the needle to the newly-established shunting point B. Then, press the **[L]** key.

- (6) Press the numeral key **[1]** and the **[−]** key. The tip of the needle will move to the shunting point A.
- (7) Press the **[C]** key, the numeral key **[1]**, and the **[+]** key in that order. The shunting point A will be cancelled, and the tip of the needle will move to the newly-established shunting point B.
- (8) Press the R/W switch to write the pattern to disk. (Refer to page 24.)
- (9) Press the **[P]** key to enter the sewing mode.

7 To cancel the shunting point A

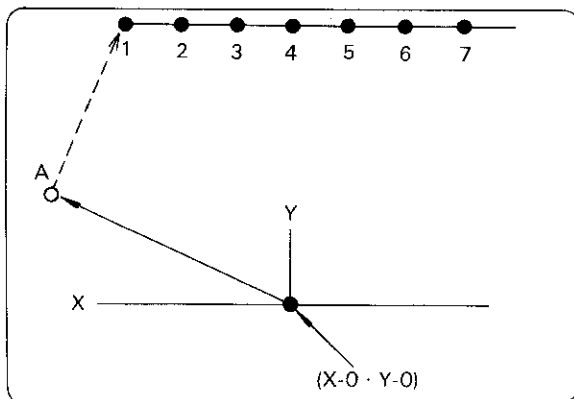

- (1) Set the power source switch to the ON position.
- (2) Press the **[P]** key. The work clamp will move to the point of origin (X-0; Y-0), the numeral "0" will be indicated on the STEP display, and the command indicator "F" will illuminate.
- (3) Insert the disk containing the stitch pattern program to perform the read operation.
- (4) Press the numeral key **[1]** and the **[+]** key. The tip of the needle will move to the shunting point A.
- (5) Press the **[C]** key, the numeral key **[1]**, and the **[+]** key in that order. The shunting point A will be cancelled, and the tip of the needle will move to the initial stitch position.

- (6) Press the R/W switch to write the pattern to disk. (Refer to page 24.)
- (7) Press the **[P]** key to enter the sewing mode.

8 To parallel-shift a programmed stitch pattern in the X axis or Y axis

A. When the initial stitch is the beginning of the sewing operation.

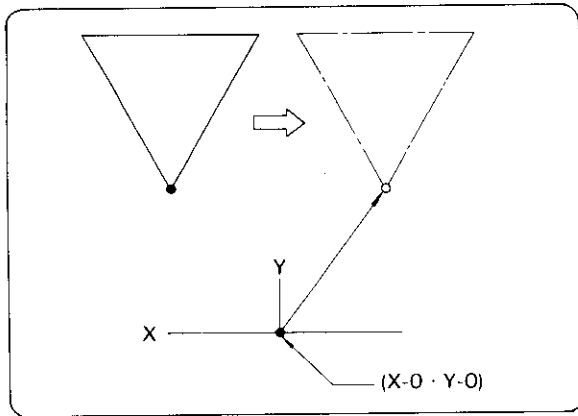

- (1) Set the power source switch to the ON position.
- (2) Press the **[P]** key. The work clamp will move to the point of origin (X-0; Y-0), the numeral "0" will be indicated on the STEP display, and the command indicator "F" will illuminate.
- (3) Insert the disk containing the stitch pattern program to perform the read operation.
- (4) Operate the direction keys to move the tip of the needle to the newly-established starting position of the sewing operation. Then, press the **[L]** key.
- (5) Press the R/W switch to write the pattern to disk. (Refer to page 24.)
- (6) Press the **[P]** key to enter the sewing mode.

B. When the initial stitch is the shunting point of the sewing operation.

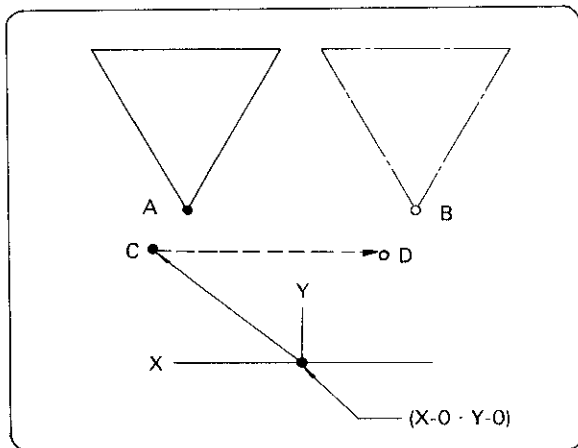

- (1) Set the power source switch to the ON position.
- (2) Press the **[P]** key. The work clamp will move to the point of origin (X-0; Y-0), the numeral "0" will be indicated on the STEP display, and the command indicator "F" will illuminate.
- (3) Insert the disk containing the stitch pattern program to perform the read operation.
- (4) Press the numeral key **[2]** and the **[+]** key. The tip of the needle will move to point A.
- (5) Operate the direction keys to move the tip of the needle to point B. (At this time, do not press the **[L]** key.)

Note When the distance from point A to point B exceeds 6.2 mm, press either the **[L]** key or the **[F]** key, and then operate the direction keys to move the tip of the needle to point B.

- (6) Write down the coordinates (the X and Y values) on a piece of paper.
- (7) Press the **[R]** key. The work clamp will move back to the point of origin.
- (8) Press the numeral key **[1]** and the **[+]** key. The tip of the needle will move to point C.
- (9) Operate the direction keys according to the value of the coordinates in the X and Y axis to move the tip of the needle to point D.

Note If the distance the pattern is to be moved (the distance between A and B) is greater than 8.0 mm, press the **[L]** or **[L]** key, press the feed key, and move the needle point to point D.

- (10) Make a mark at point D so that the tip of the needle can easily be brought to this position when the pulley is turned manually.
- (11) Turn the pulley manually to raise the needle to the highest position.
- (12) Press the **[R]** key. The work clamp will move back to the point of origin.
- (13) Operate the direction keys to move the tip of the needle to point D (i.e., to where the mark was made.) Then, press the **[L]** key.
- (14) Press the R/W switch to write the pattern to disk. (Refer to page 24.)
- (15) Press the **[P]** key to enter the sewing mode.

9 To cancel points 7 and 8 after locating an error in the program.

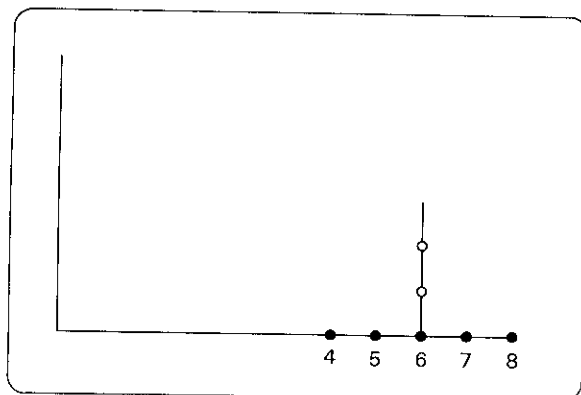

- (1) Press the **[C]** key. The command indicator "C" will illuminate.
- (2) Operate the direction keys to indicate on the STEP display the number of steps to be cancelled. In this instance, points 7 and 8 are to be cancelled. Therefore, indicate "002" on the STEP display.
- (3) Press the **[←]** key. The tip of the needle will move from point 8 to point 7 and then to point 6. Thus, point 8 and 7 will be cancelled.
- (4) Reprogram the stitch pattern from point 6 onward.

10 To shift a pattern B that is in the middle of consecutively programmed patterns

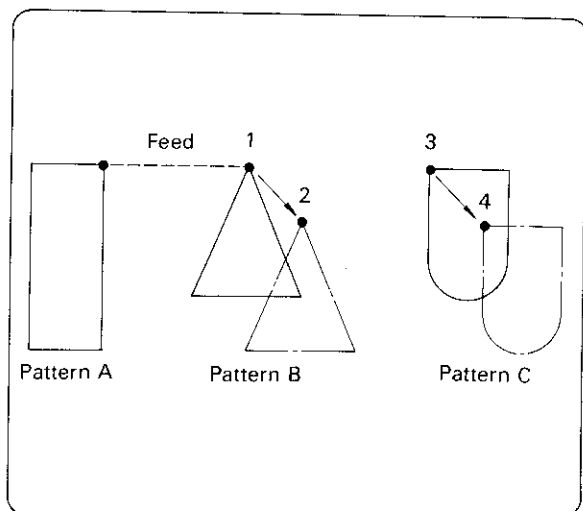

- (1) Set the power source switch to the ON position.
- (2) Press the **[P]** key. The work clamp will move to the point of origin (X-0; Y-0), the numeral "0" will be indicated on the STEP display, and the command indicator "F" will illuminate.
- (3) Insert a disk into the drive.
- (4) Press numeral key **[9]** 3 times to indicate "999" on the STEP display, and then press the **[+]** key. The needle tip should now trace pattern A one stitch at a time.
- (5) Press the **[+]** or **[←]** keys so that the needle tip aligns with the first stitch of pattern B. The work clamp will stop. (If the work clamp moves past the first stitch of pattern B, use the number keys to display that number of stitches in the STEP display and then press the **[←]** key. The work clamp will now return the number of stitches displayed in the indicator.)

- (6) Press the numeral key **[7]** 3 times to indicate "777" on the STEP display and then press the **[F]** key.
- (7) Use the feed key to move the needle tip from point 1 to point 2, and then press the **[L]** key.

Note If a third pattern "C" follows pattern B, pattern C will automatically follow pattern B and shift as shown in the diagram. If this is undesirable, follow the same procedure as in steps (4) ~ (7) above to move the needle tip to point 3, and use the "777 F" code to return pattern C to its original position.

- (8) Press the R/W switch to write the pattern to disk. (Refer to page 24.)
- (9) Press the **[P]** key to enter the sewing mode.

11 To set a constant sewing speed irrespective of stitch length

- The sewing speed on this machine is normally controlled automatically according to the selected stitch length. This sewing speed can be reprogrammed to a constant speed, however, for better results in zigzag patterns and with extremely thick materials.

- (1) Input "112" **[E]** at the end of the program instead of "111" **[E]**. The sewing speed will be 600 ~ 1,000 spm irrespective of the selected stitch length.

Note Disks with patterns programmed for 600 ~ 1,000 spm should still be ended with "111" **[E]**. The sewing speed will remain as programmed.

12 When thread trimming is not used at the sewing end

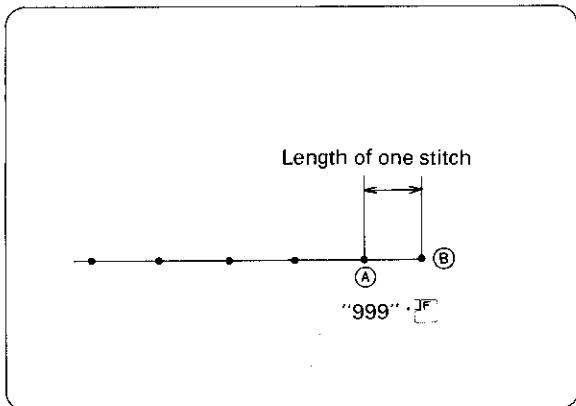

- Basting can be ended without thread trimming.
- (1) Program to point **A**, one stitch before the last stitch **B**.
 - (2) Press numeral key **9** three times at point **A** to display "999" in the STEP display, and then press **F**.

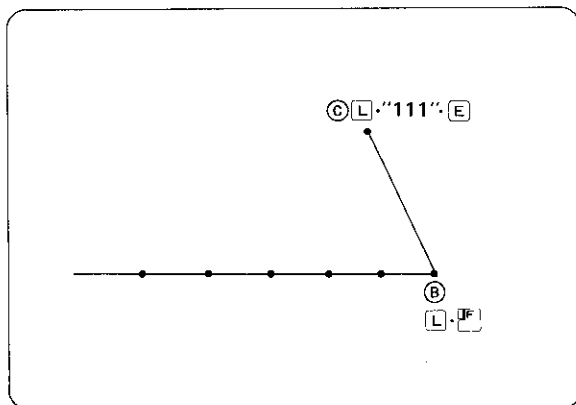

- (3) Use the direction keys to position the needle at **B**, and then press **L**.
- ※ The distance from **A** to **B** is the length of one stitch.
- (4) Feed to any point **C**.
- ※ If the machine is not fed to add a point **C** after the last stitch **B**, thread trimming will be performed at point **B**.
- (5) Press **L** at point **C**.
- (6) Press numeral key **1** three times. Confirm that "111" is in the STEP display, and then press **E**.

HOW TO USE AND MAINTAIN THE FLOPPY DISK

* Follow the suggestions mentioned below to obtain the maximum useful life of the micro disk.

- 1** Do not touch the magnetic surface of the memory disc. Fingerprints not only cause the disk to become dirty, but also always cause an error in the program.

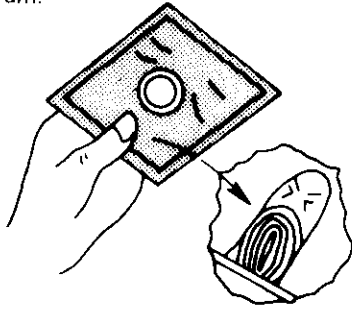

- 2** Do not bring solvents into contact with the magnetic surface of the disk. Avoid the use of thinner, alcohol, freon, etc.

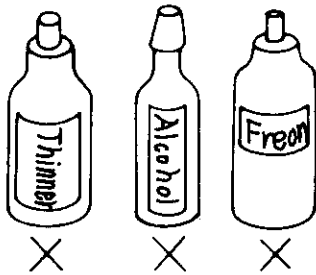

- 3** Do not bring magnets in the vicinity of the micro disk. Exposure to magnetic fields may result in erasure of the program on the memory of the disk. Be sure to avoid the use of magnetic paper stoppers, etc. on the micro disk.

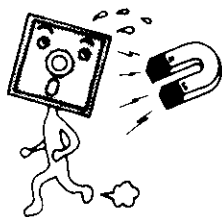

- 4** Do not expose the disk to direct sunlight or bring it in the vicinity of a heating appliance.

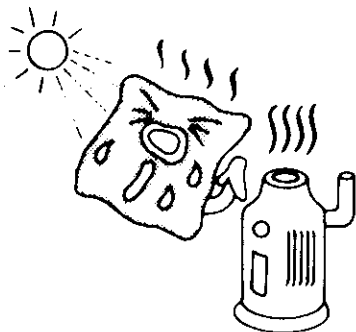

- 5** The disk should be used under the following conditions:
 Temperature: 10° ~ 15°C
 Humidity: 20% ~ 80% r/h
 However, wet-bulb temperature: less than 29°C
 (Avoid the use of the disk when abrupt changes in temperature occur.)

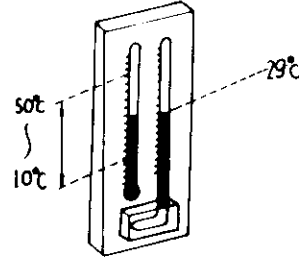

- 6** The disk should be stored under the following conditions:
 Temperature: 4° ~ 53°C
 Humidity: 8% ~ 80% r/h

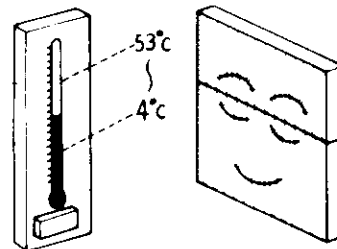

- 7** The disk should be transported under the following conditions:
 Temperature: 40° ~ 53°C
 Humidity: 8% ~ 90% r/h
 Be sure to keep the disks stored in an appropriate box during transportation.

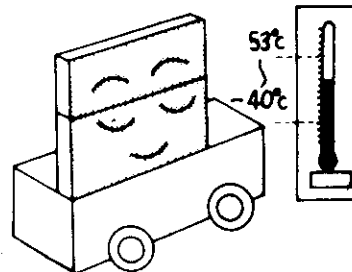

ブラザー工業株式会社

〒467 名古屋市瑞穂区河岸一丁目1番1号
TEL (052) 824-2392代

BROTHER INDUSTRIES, LTD. NAGOYA, JAPAN

151-326
192326-012
1989.09 ①

Printed in Japan/Gedruckt in Japan/Imprimé au Japon/Impreso en Japón