

bro rom

INDUSTRIAL MACHINES

Str. Fabrica de Glucoza 2-4, sector 2, Bucuresti, Romania

Tel./Fax: +01 2323.844, +01 232.969, +01 2323.87

www.brother.ro ww.brorom.ro mail:office@brother.ro

www.pieseschimb.masinidecusut.ro

SINGLE HEAD ELECTRONIC EMBROIDERY MACHINE

<Cap frame attachment>

<Boring attachment>

BAS-410

INSTRUCTION MANUAL

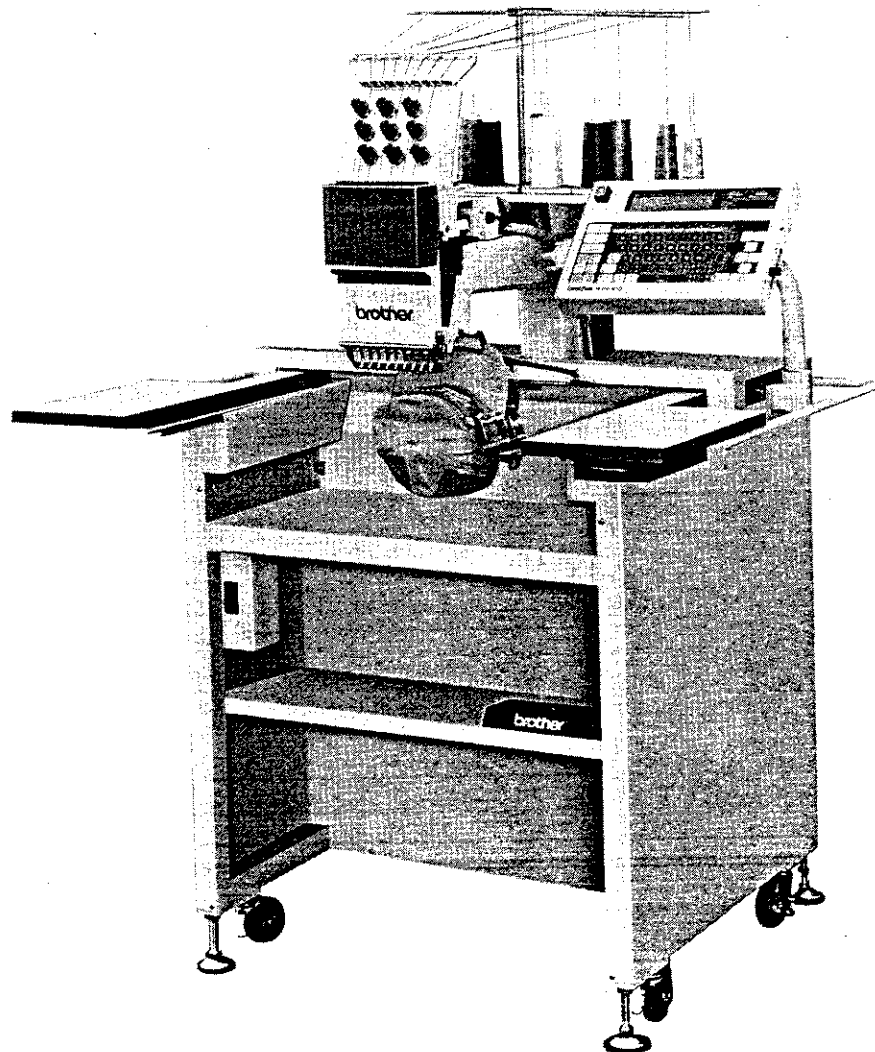

INTRODUCTION

This instruction manual contains a parts list for the cap frame attachment and the boring attaching in addition to instructions for both assemblies. Please be sure to read these instructions carefully for full use of all functions and features.

CONTENTS

FEATURES	1
PREPARATION	1
1 Items required for installation	
Cap frame attachment	1
Boring attachment	1
2 Installation of the cap frame attachment	2
3 Operation	9
4 Setting the cap frame set frame, cap frame, and cap	10
5 Removing the cap frame attachment for standard use	13
6 Reinstalling the cap frame	14
7 Installing the boring attachment	15
8 Operation	16
PARTS LIST	18
1 Cap frame attachment	18
2 Boring attachment	22

FEATURES

1. The available sewing area measures $X = 140 \text{ mm}$, $Y = 68 \text{ mm}$, enabling embroidery on round caps.
2. Cap frame and boring attachments create higher added value with embroidery on standard products.

PREPARATION

1 Items required for installation

(1) Cap frame attachment

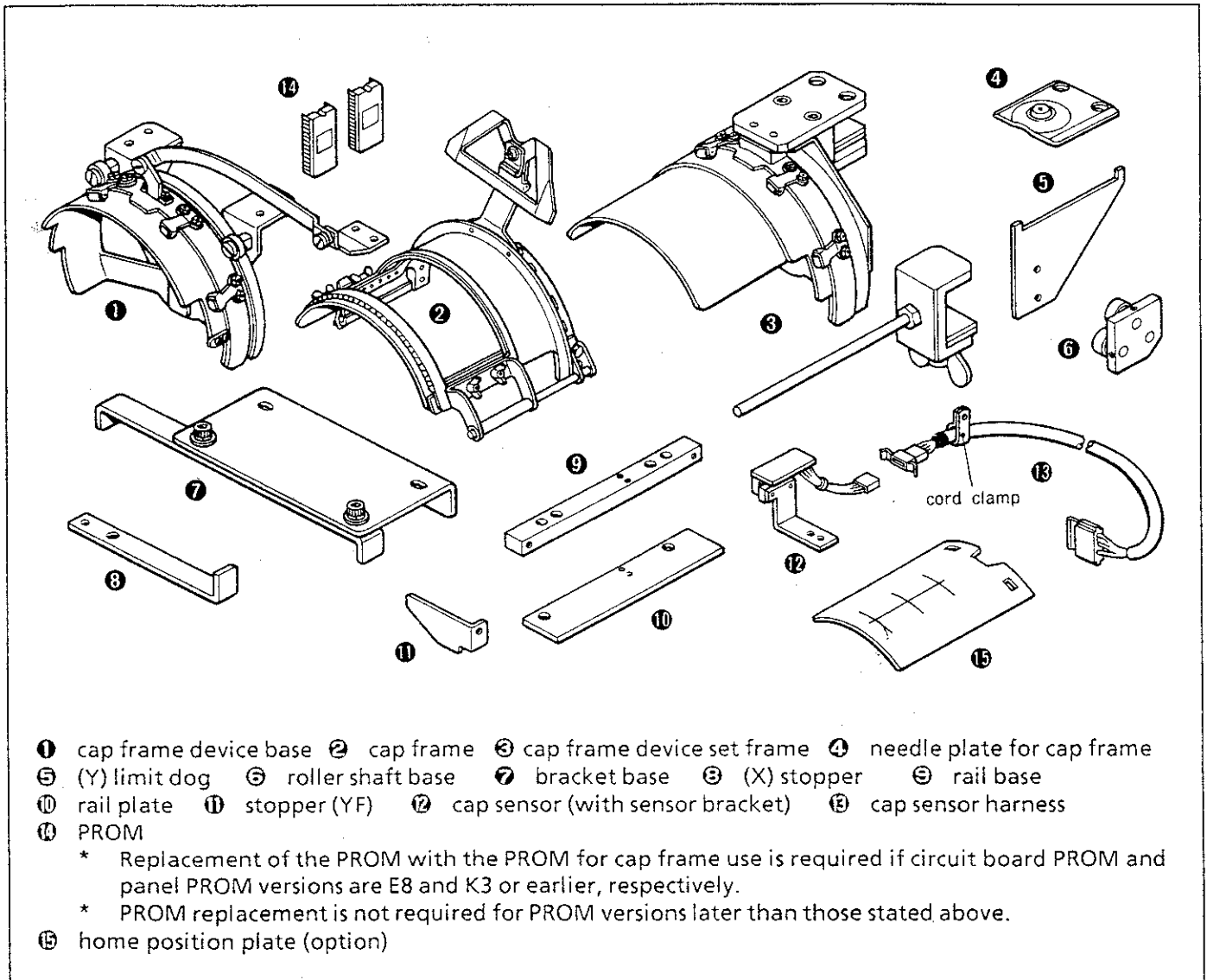

(1) Boring attachment

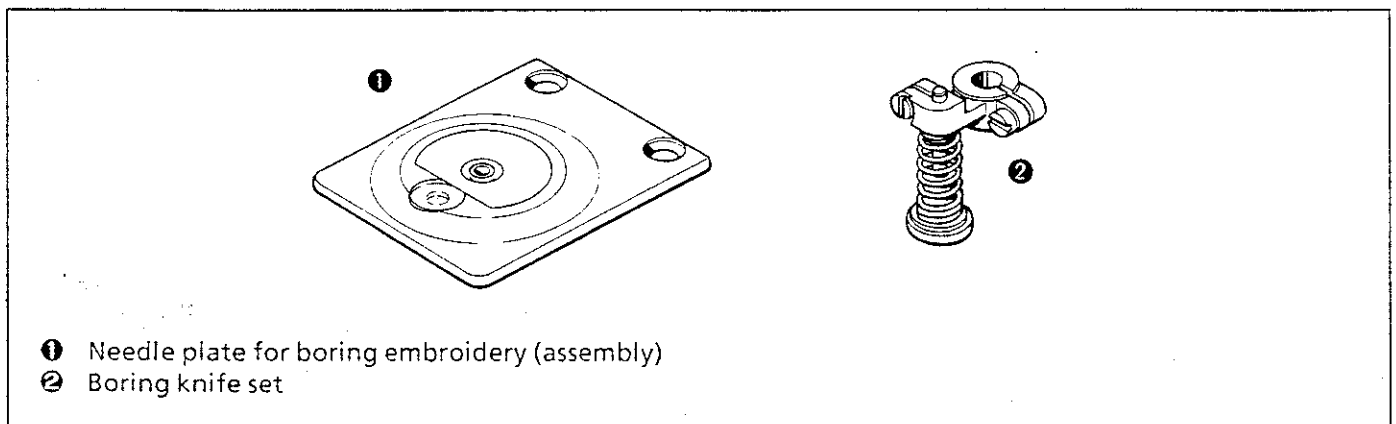

PREPARATION

② Installation of the cap frame attachment

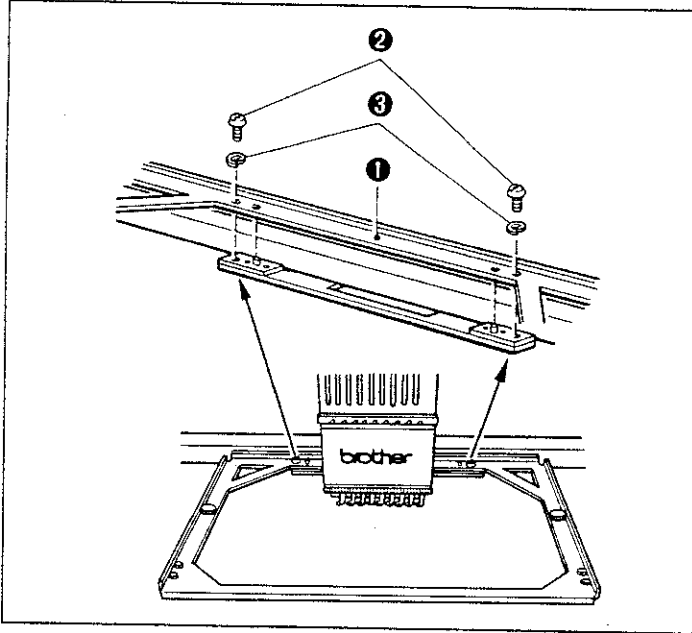

* Be sure to turn the power off before proceeding with installation.

- (1) Loosen the two set screws ② with spring washers ③ for the flat frame ①, and remove the flat frame ① from the machine.

NOTE: The screws and spring washers removed in this step will be used later. Do not lose them.

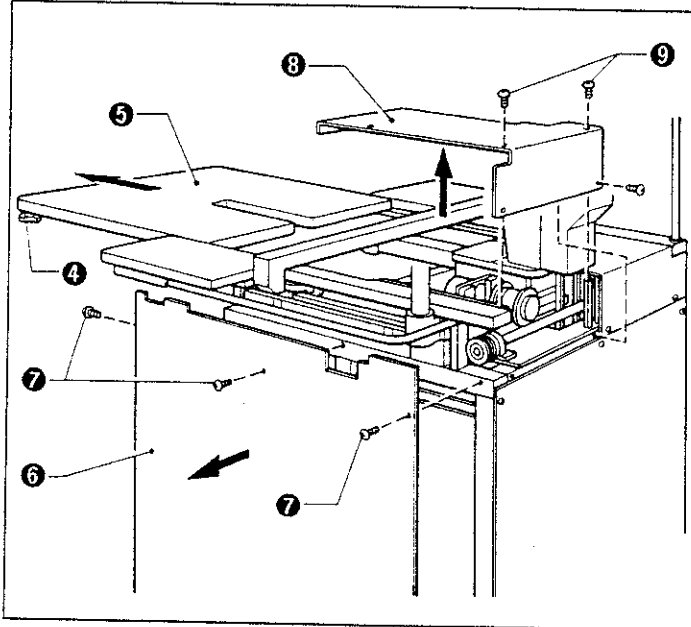

- (2) Loosen the two clamp bolts ④, and slide table (C) ⑤ off to the front.

- (3) Loosen the six set screws ⑦ to remove cover (RD) ⑥.

Loosen the five screws ⑧ and remove table (RR) ⑨.

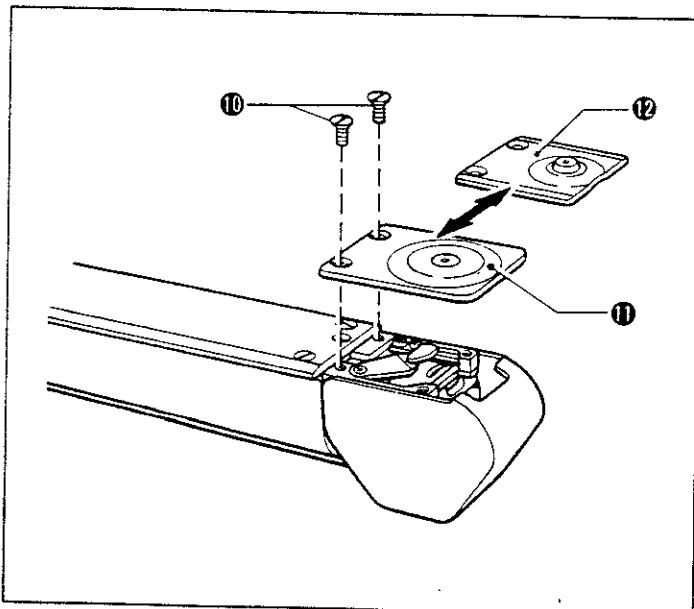

- (4) Loosen the two screws ⑩, and replace the needle plate ⑪ with the needle plate ⑫ for the cap frame.

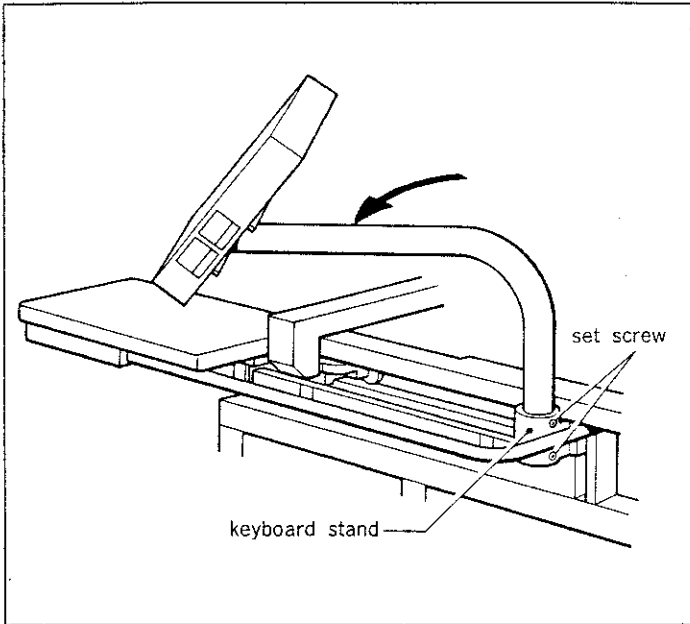

- * If the current PROM version is 1 - 8, replace the PROM as described in steps (5) - (8) below.
- * Replacement is not required for PROM version no. 9.

NOTE 1: If PROM replacement is required, replace the two PROMs on the main circuit board and the keyboard circuit board.

NOTE 2: For easier PROM replacement, loosen the two set screws on the keyboard stand to move the stand.

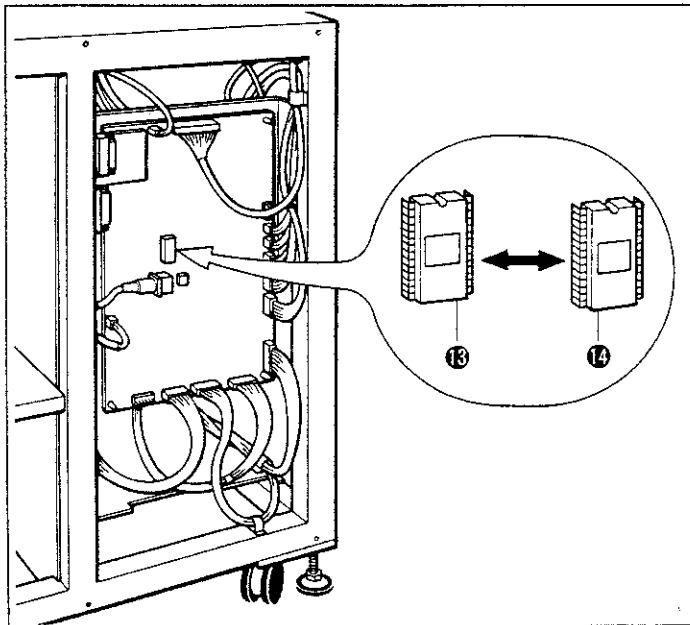

[Main circuit board]

- (5) Remove the PROM 18 on the main circuit board 19, and replace it with the PROM 14 for the cap frame.

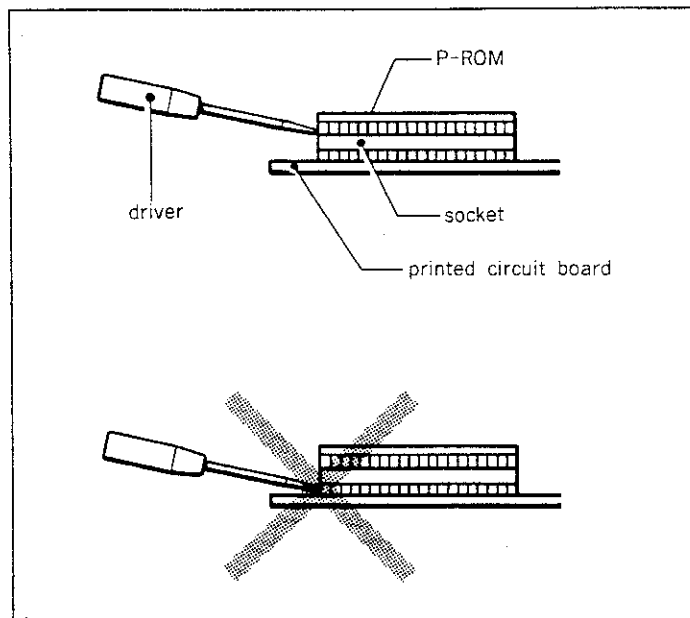

Notes:

1. Use care when handling the PROMs. Make sure the pins are properly inserted in the sockets.
2. Do not apply excessive force when mounting the PROM on the circuit board.
3. Confirm that the PROMs are in the correct position and direction.
4. Use of the special PROM removal tool is recommended when removing the PROM. If a screwdriver must be used, be careful not to damage the PROM socket. Carefully lift the PROM little by little from both sides. See the figure.

PREPARATION

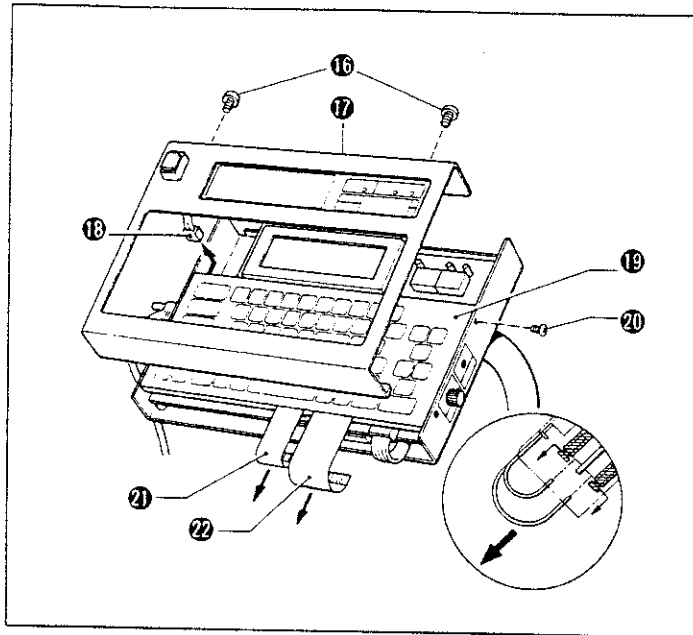

[Keyboard circuit board]

- (6) Loosen the two screws ⑬ and pull the panel ⑰ slightly forward and off.

NOTE-3: Be careful when removing panel ⑰ because the cord for the emergency stop switch ⑱ is short.

- (7) Loosen the four screws ⑲, and remove the support ⑳.

NOTE: Pull the black connector connecting the two flat cables ㉑ and ㉒, release the connector lock, and pull the cables forward and out.

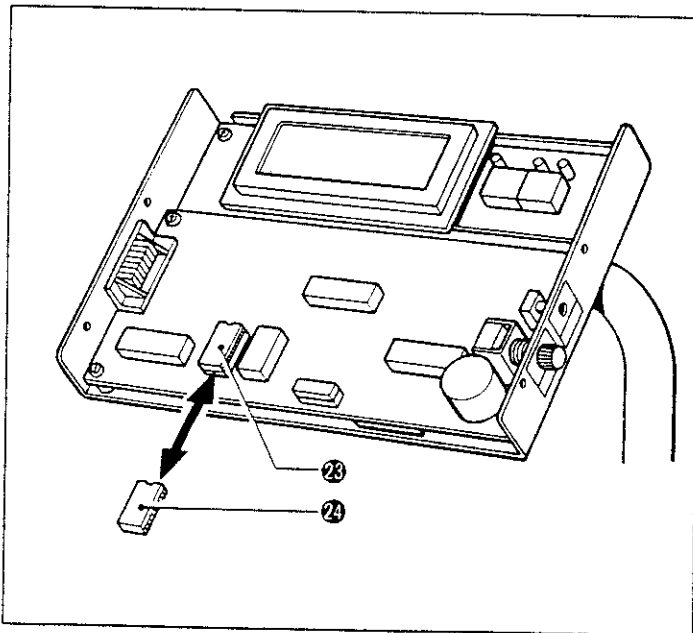

- (8) Remove the PROM ㉓ on the keyboard circuit board, and replace it with the PROM ㉔ for the cap frame.

* Following the cautions described above for PROM installation.

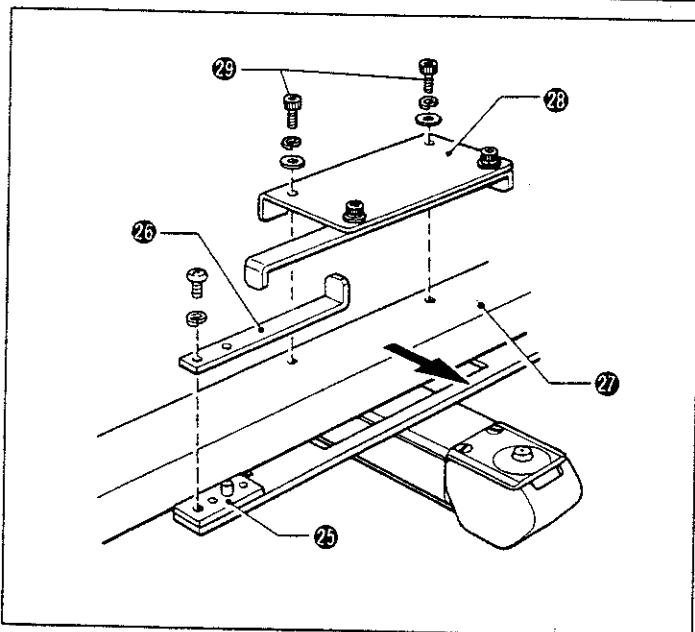

- (9) Install the X dog ㉕ with the screws removed earlier in step (1) at the installation place ㉖ on the left side.

* Pull the carriage forward to install the X dog.

- (10) Install the carriage cover ㉗. Remove the two screws ㉘, and install the bracket base ㉙.

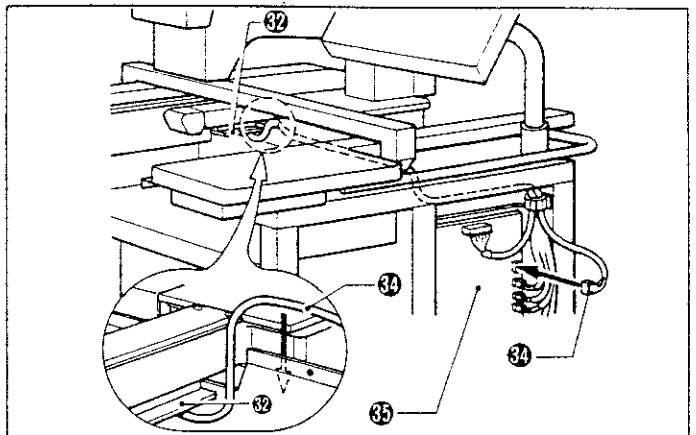
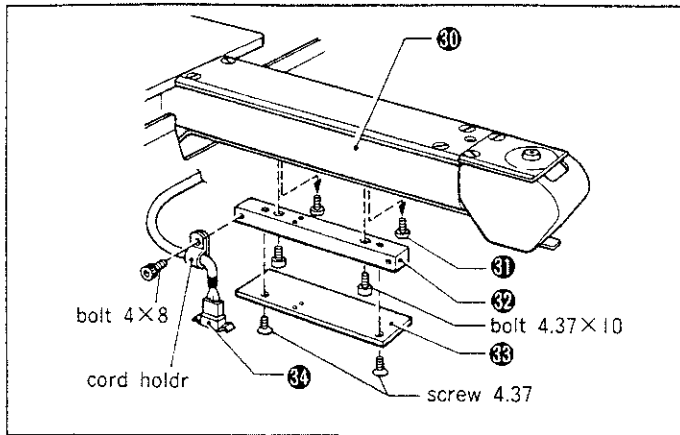

(11) Remove the two set screws ① below the bed ⑩.

NOTE: If the two screws ① are not there, simply proceed as follows.

(12) Install the rail base ⑭ and then the rail plate ⑮ below the bed ⑩.

Install the Y sensor cord ⑫ to the rail base ⑭ at this time.

(13) Set the Y sensor cord ⑫ installed in the rail base ⑭ into P-12 ⑬ on the main circuit board.

* Fasten the cord at two places in the middle with cable stays.

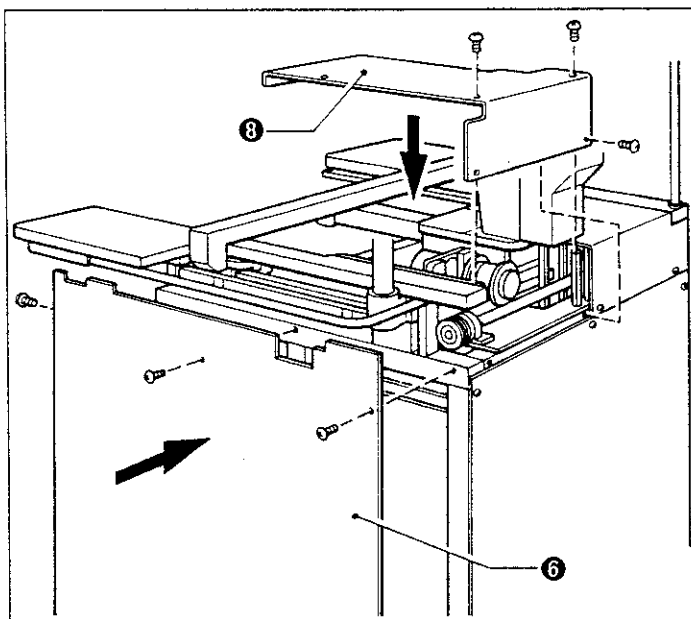

(14) Install cover (RD) ⑧ and table (RR) ⑥ with the respective screws.

PREPARATION

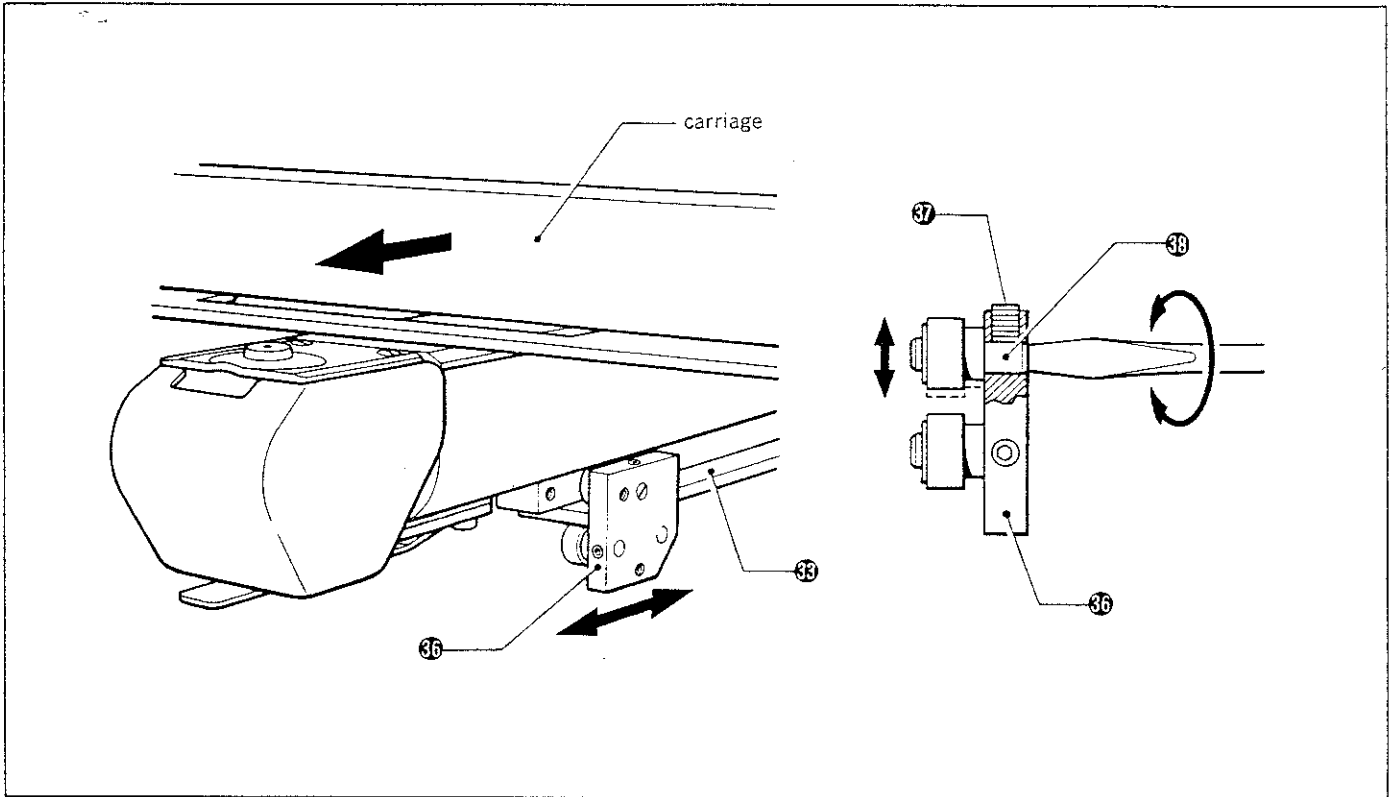

- (15) Fit the roller bearing base 36 on the rail plate 33 with the carriage pulled all the way forward. Make sure the roller bearing base 36 moves smoothly. To adjust, loosen set screw 37 and adjust eccentric screw 38.

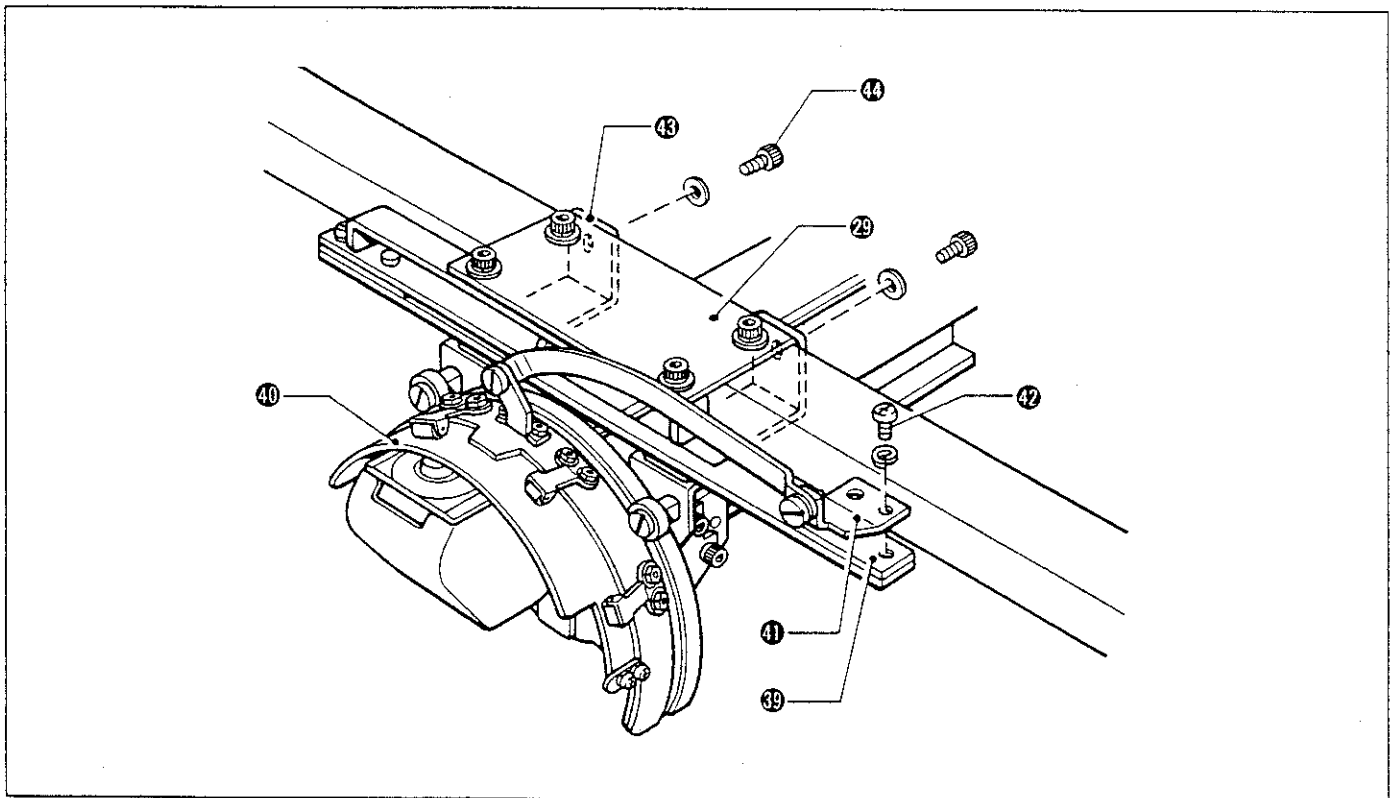

- (16) Install the cap lever drive plate 41 of the frame base 40 to the right side (carriage) 39 of the flat frame with set screw 42.
Install the L-bracket 43 on the cap frame base 40 to the bracket base 42 with two bolts 44.

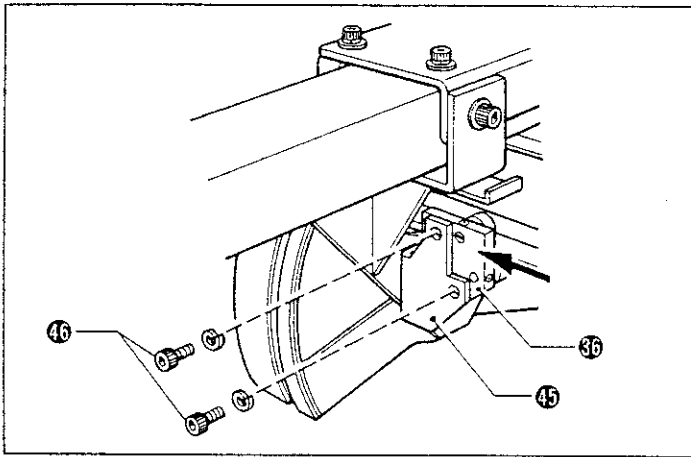

(17) Install the roller bearing base 45 to the U bracket 46 with two bolts 47.

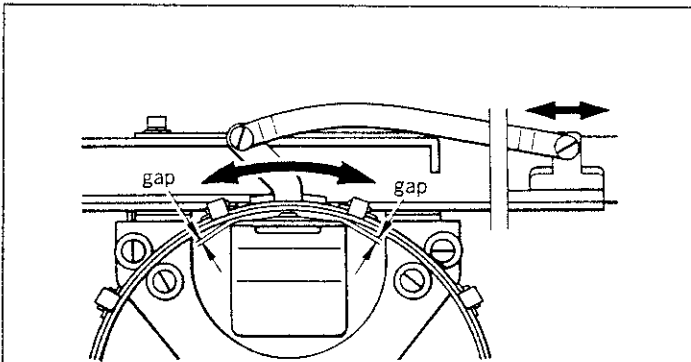

Turn the cap frame by hand, and make sure that the cap frame does not contact the bed at any point throughout a full rotation of the frame.

(The gap between the cap frame and the bed should be as close as possible, with a maximum 1 mm gap.)

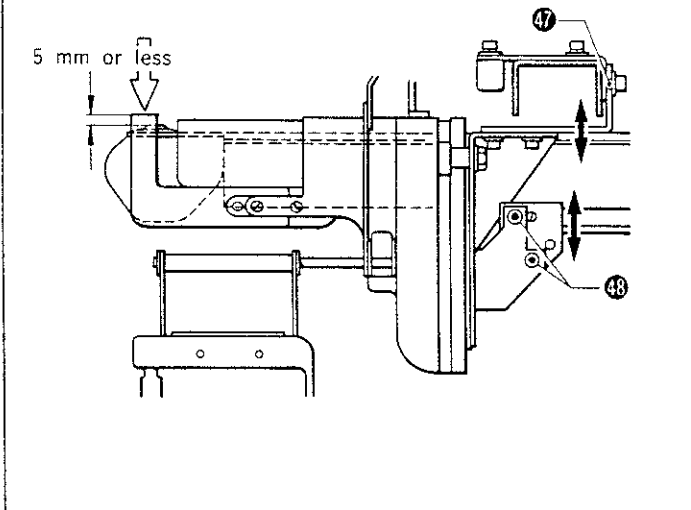

Install the cap frame, and make sure that the front edge is not too far off the needle plate and is level with the bed face. (The gap between the front edge and the needle plate should be 1 mm or less.)

[Adjustments]

1. To adjust, loosen the screw 48 and press the front edge of the cap frame to the needle plate top, then re-tighten the screw 48.

NOTE: Install the cap frame. The gap between the base frame top and the protrusion of the needle plate should be maximum 5 mm.

2. When the cap frame contacts the bed after adjustment 1, loosen the screws 47 and 48, raise the whole of the cap frame and tighten the screw 47, then redo step 1.

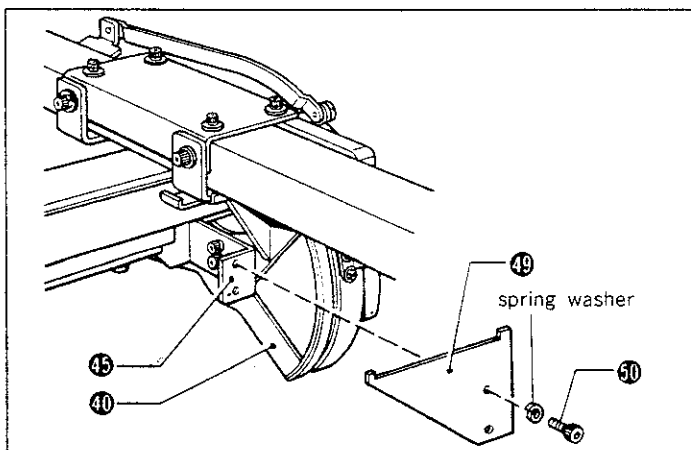

(18) Install the Y limit dog 49 to the U bracket 45 on the cap frame base 40 with the two bolts 50.

PREPARATION

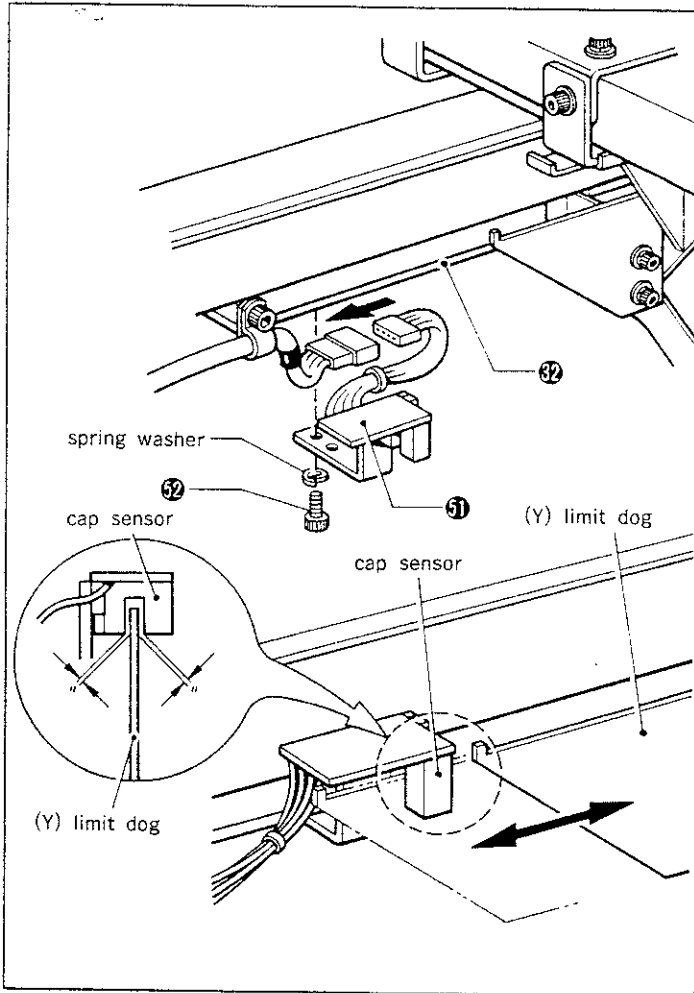

- (19) Temporarily secure the cap sensor (assembly) 51 to the rail plate 32 with the two bolts 3 x 6 32

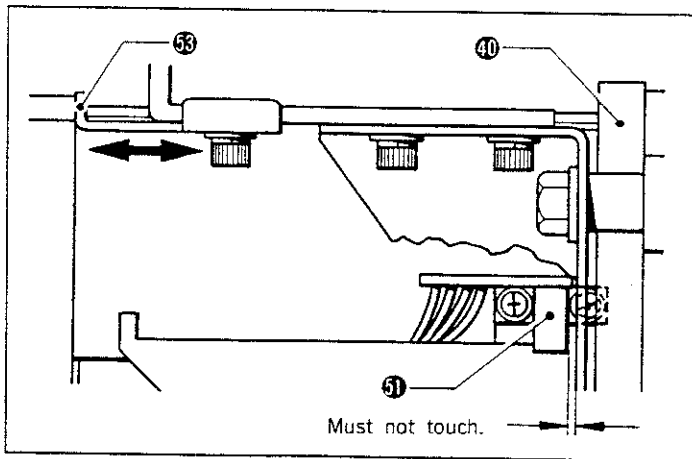

- (20) Adjust the position of stopper (YR) 53 by moving the carriage. Confirm that the cap frame base 40 and the cap sensor 51 do not touch.

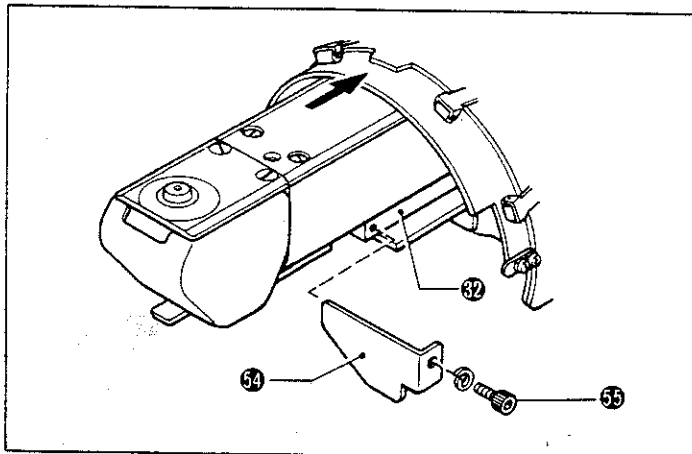

- (21) Install stopper (YF) 54 to the rail base 32 with bolt 55

* Reconfirm that no parts touch during operation, and then firmly tighten all screws.

3 Operation

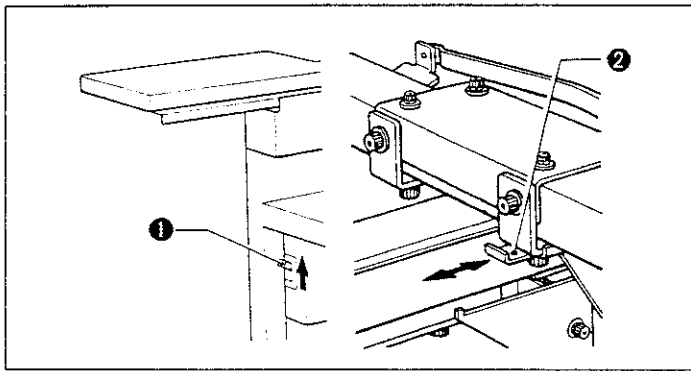

[When using the optional home plate]

[ENTER] [EDIT]
[COMMUNICATE]
[START (Sewing)]

0

2

① ENCOD ② Ov-TRVL
P-ROM Ver *
P-ROM Ver *

① +X ② -X ③ +Y ④ -Y

END

Turn the power switch ❶ on.

- * If out of adjustment, immediately turn the power off and adjust the length of stopper YR ❷.
- * If the power is turned on when the cap sensor connector is connected, the cap frame presser mode will be automatically set.

(Edit contents)

② ARA : V 68 mm H 140 mm
⑦ Rotat : 180°

To change the above settings, refer to the instruction manual for the sewing machine.

- (1) Turn the power on ❶, and confirm the home position Ⓐ.
- (2) Enter 0 with the number keys.
 - * Fine adjustments are made in the home position confirmation mode. The screen will change to the test mode.
- (3) Press number key 2 to select travel.
- (4) Press number key 3 to move the cap frame base ❸ to the inside. Confirm that the needle has descended, and the home plate Ⓑ position.
- (5) Press the END key.
- (6) Press number key 4 to move the cap frame base ❸ forward.
 - * The feed will move to home position Ⓐ in the home plate.
 - * Check and adjust as required the direction of rotation, and the front-back tilt and gap of the cap base.
- (7) Press the END key.
- (8) Press the END key to return to the main menu.

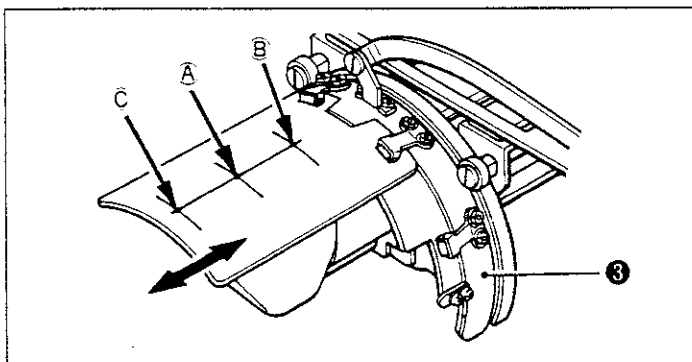

PREPARATION

4 Setting the cap frame set frame, cap frame, and cap

Mount the cap frame set frame ① firmly to the work table with the wing nut ②.

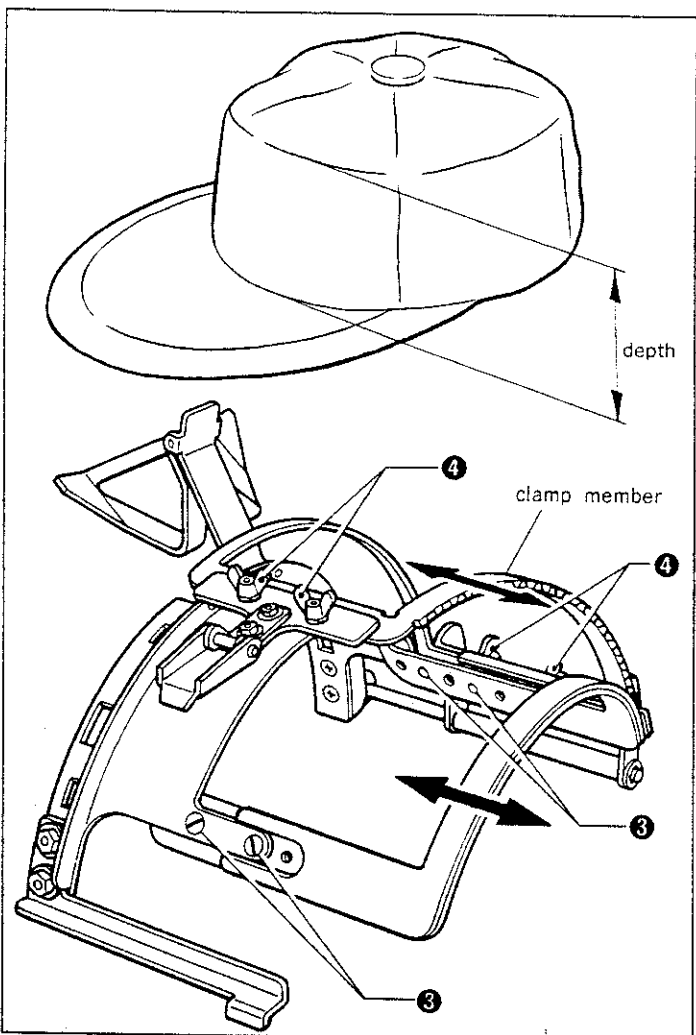
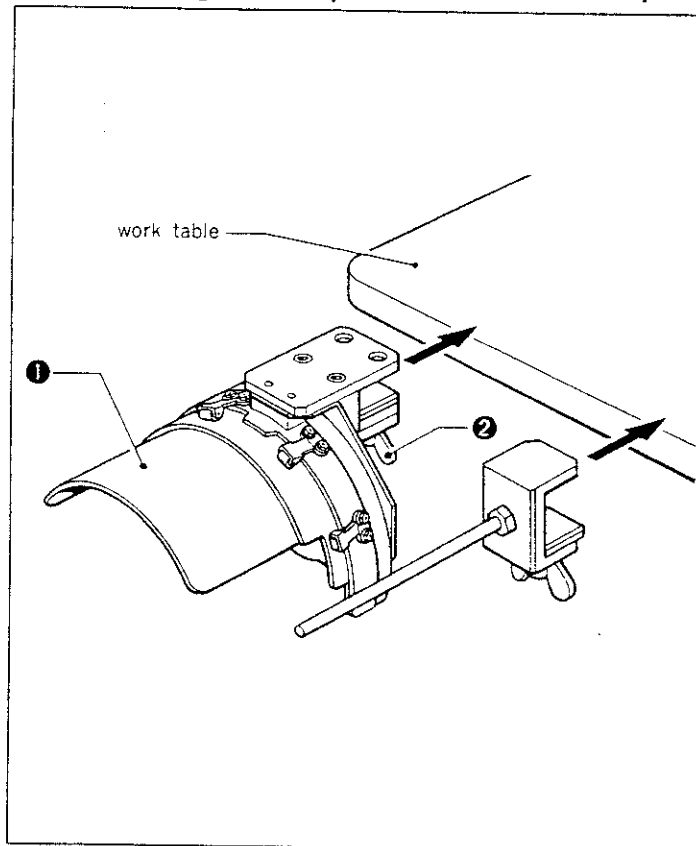

[Adjusting cap frame size]

- (1) The frame size must be adjusted according to the depth of the cap.
- (2) The frame can be adjusted to three sizes by removing the four set screws ③. Adjust the size according to the size of the cap. Also loosen the four wing nuts ④ to adjust the cap frame to the cap size.

* The clamp member can be telescoped to adjust to the material thickness by loosening the four wing nuts ④.

(3) Set the cap frame ⑤ in the set frame ①.

NOTE: Be sure to set the cap frame firmly into the set frame guides.

(4) Release the snap lock ⑥ on the cap frame ⑤ to set the cap ⑦.

NOTE: Set the cap visor firmly in the visor holder ⑧ and pull the lining inside the cap down.

(5) Close frame cover A ⑨ and lock the snap lock ⑥.

NOTE: Tighten the material on the cap to the inside so that there are no wrinkles where the cap is to be embroidered.

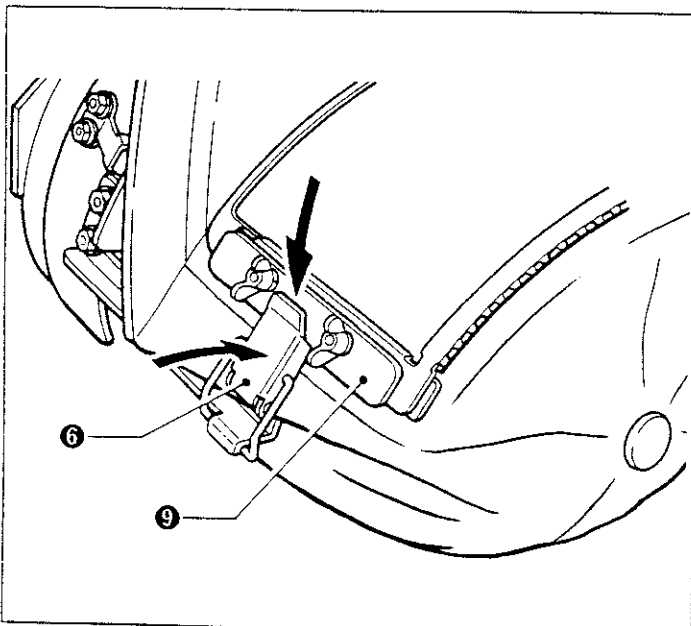
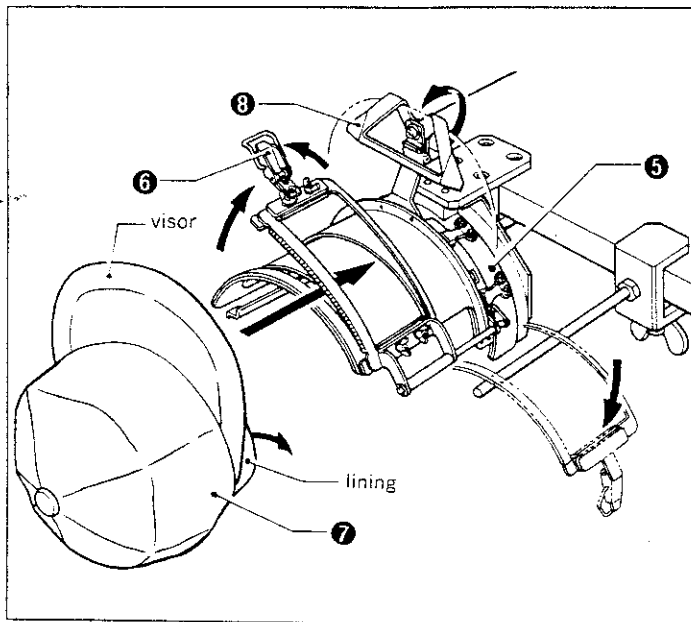
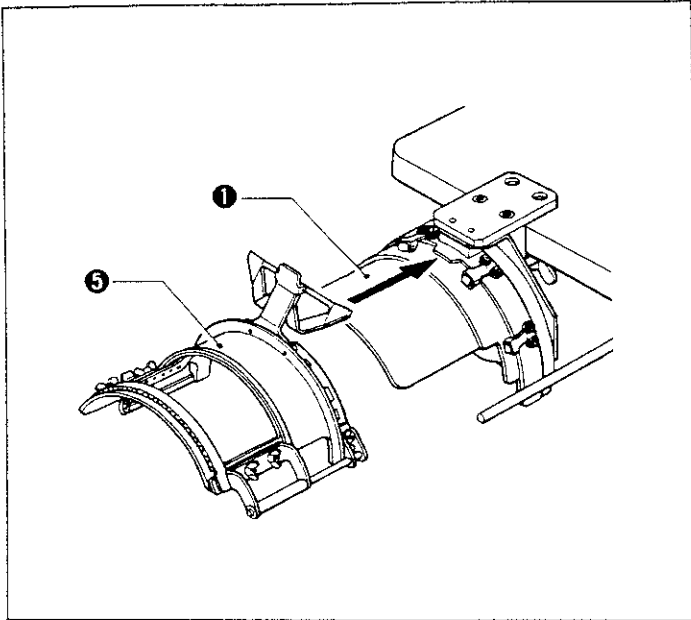

PREPARATION

NOTE: To prevent problems caused by thread remainders, program the thread trimming location at least 5 mm from the inside edge (visor seam).

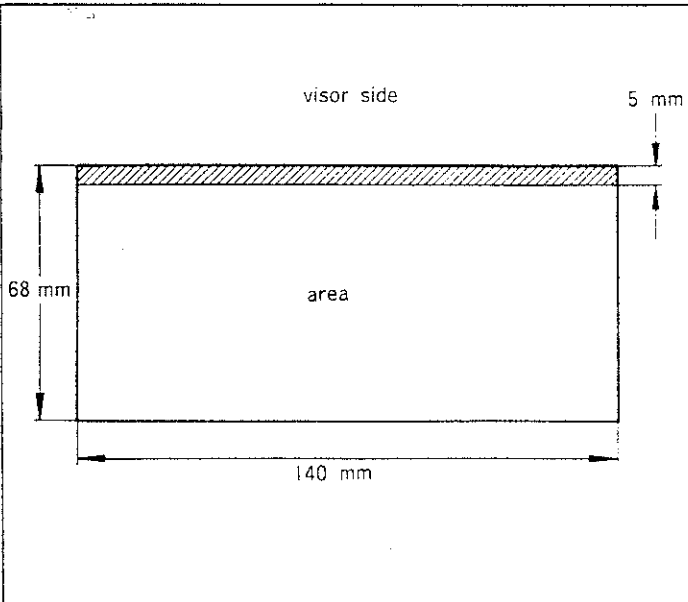

(6) Remove the cap frame ⑤ from the set frame ①, and set it on the cap frame base ⑩ mounted on the machine.

(7) Refer to the BAS-410 instruction manual for data entry and starting sewing.

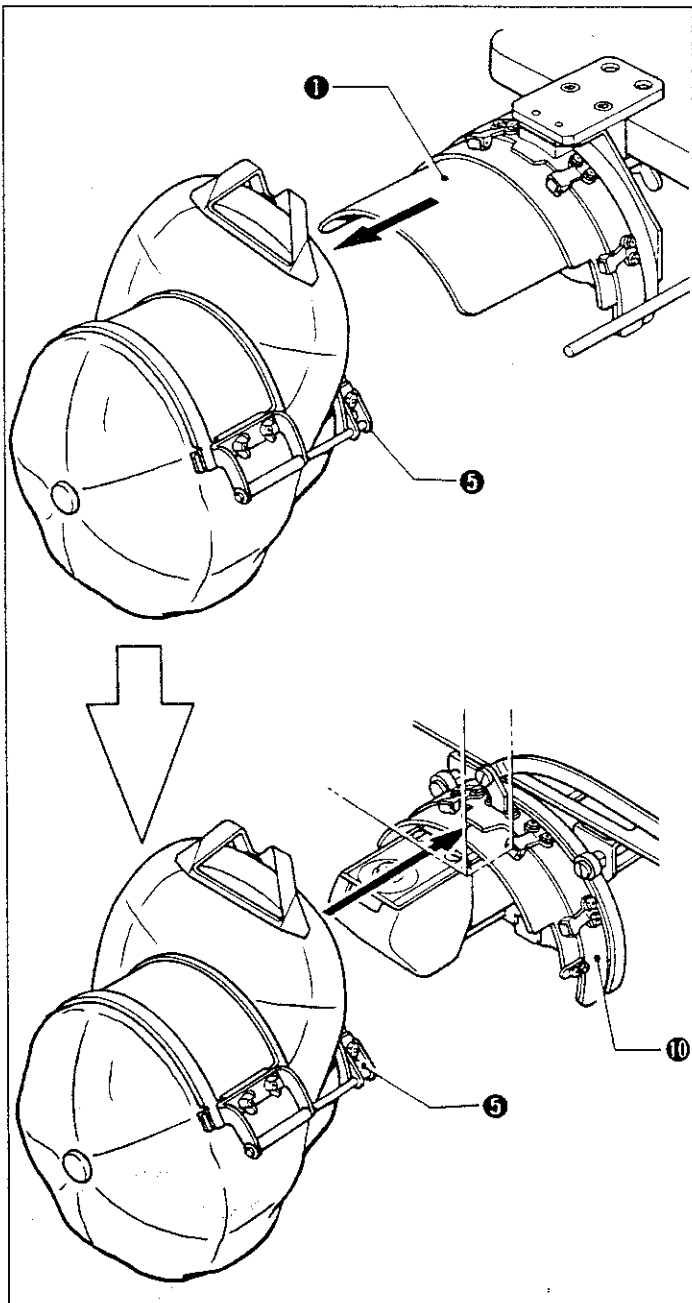

5 Removing the cap frame attachment for standard use

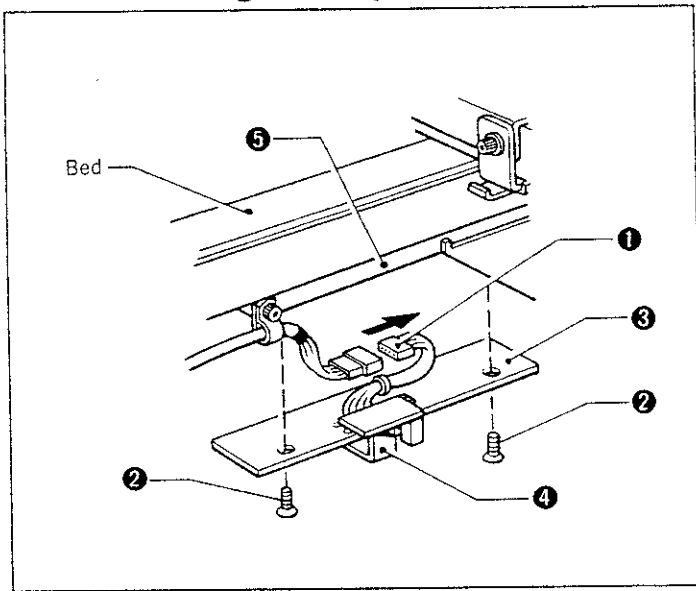

* Be sure to turn the power off before proceeding.

- (1) Remove the cap sensor connector ①.
- (2) Remove the two screws ②, and remove the rail plate ③.

NOTE: Remove the rail plate with the sensor bracket ④ mounted to the rail plate ③, being careful not to change the position of the sensor bracket.

NOTE: Leave the rail base ⑤ installed on the bed.

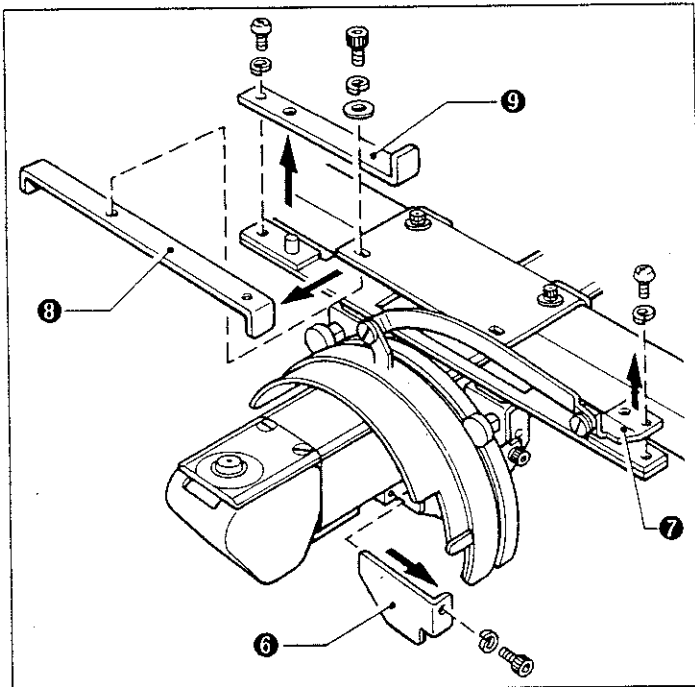

- (3) Remove stopper (YF) ⑥, lever drive plate ⑦, X limit ⑧, and X stopper ⑨.

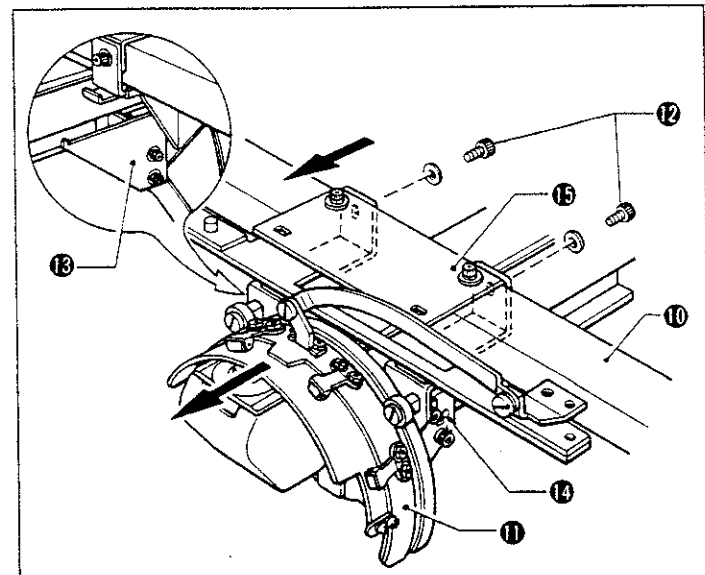

- (4) Move the carriage ⑩ forward, remove the two bolts ⑫ holding the cap frame base ⑪, and remove the cap frame base ⑪, sensor dog ⑬, and roller bearing base ⑭ as an assembly.

NOTE: Leave the bracket base ⑮ mounted on the carriage ⑩.

PREPARATION

6 Reinstalling the cap frame

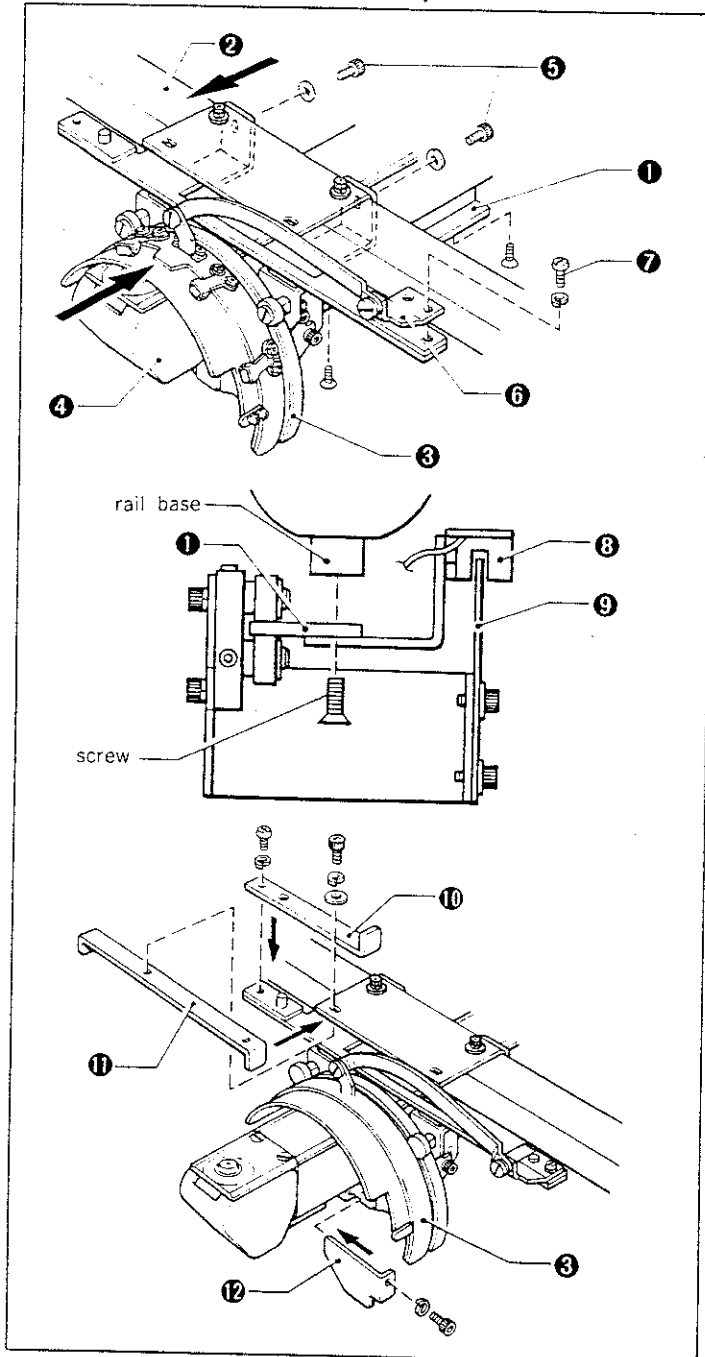

- (1) Install the rail plate ① with two screws.
- (2) Move the carriage ② forward, pass the cap frame base ③ through the bed ④, and secure temporarily with two bolts ⑤.
- (3) Install the lever drive plate ⑥ with the screw ⑦.

NOTE: Be careful with the cap sensor ③ and sensor dog ④ at this time.

- (4) Install the X stopper ⑩, X limit ⑪, and then stopper YF ⑫.
- (5) Move the cap frame base ③ forward and back to make sure the sensor ③ and sensor dog ④ do not touch, check the gap to the bed, and then firmly tighten the two temporarily tightened bolts ⑤.

NOTE: Re-adjust the gap between the cap frame and the needle plate after [Adjustments] on page 7.

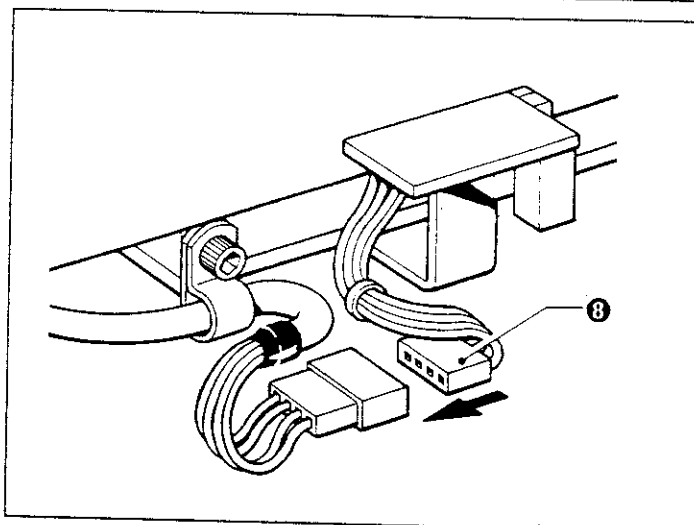

- (6) Connect the cap sensor ③.
- (7) Turn the power on and check the operation.

7 Installing the boring attachment

* Be sure to turn the power off before proceeding with installation.

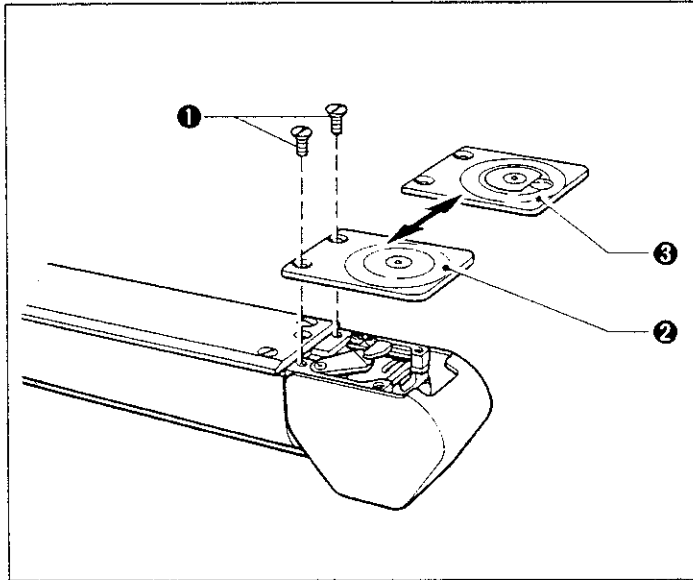

- (1) Loosen the two screws ①, remove the needle plate ②, and install the needle plate ③ for boring embroidery.

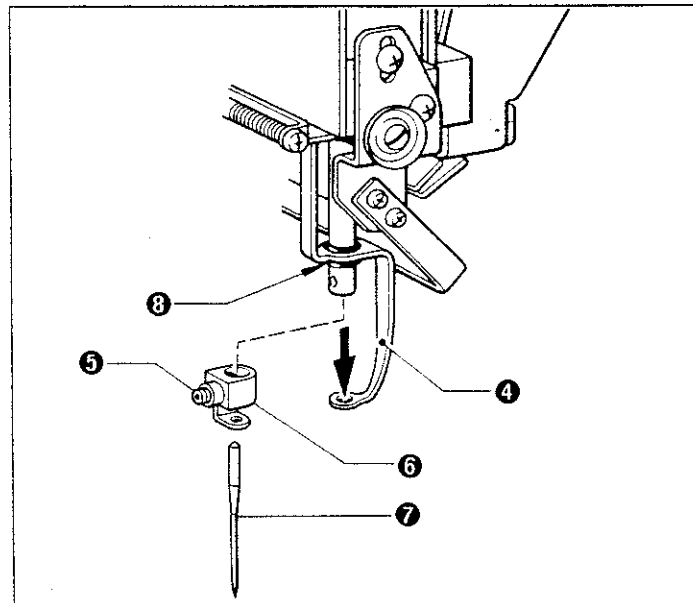

- (2) Lower the presser ④ by hand.
- (3) Loosen the needle set screw ⑤, and remove the needle clamp ⑥ and needle ⑦.

NOTE: Be careful the O-ring ③ set above the needle clamp does not drop.

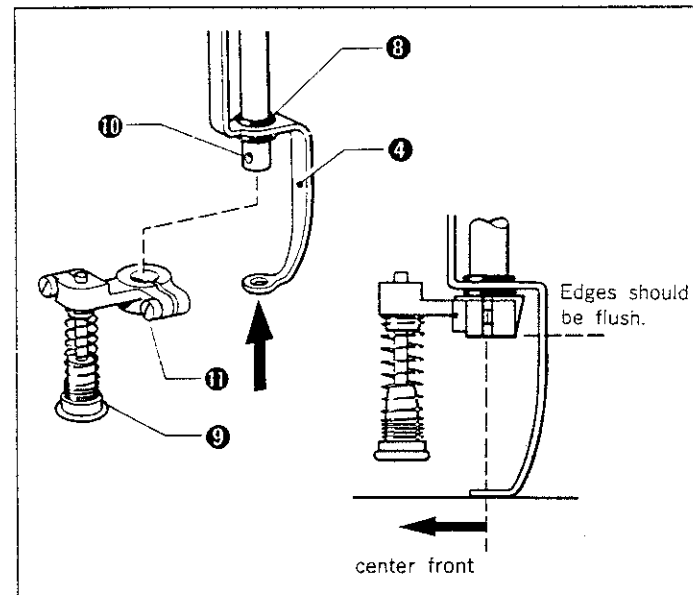

- (4) Raise the presser ④ and set the boring knife set ⑧ on the needle bar ⑩, and secure with set screw ⑨.

NOTE: The bottom of the boring knife set and the needle bar should be flush.

NOTE: Install the knife set with the point at which the knife descends at the front center of the needle bar.
Make sure the O-ring ③ is not compressed at the needle bar's highest position. If it is, slightly lower the boring knife set on the needle bar.

PREPARATION

8 - Operation

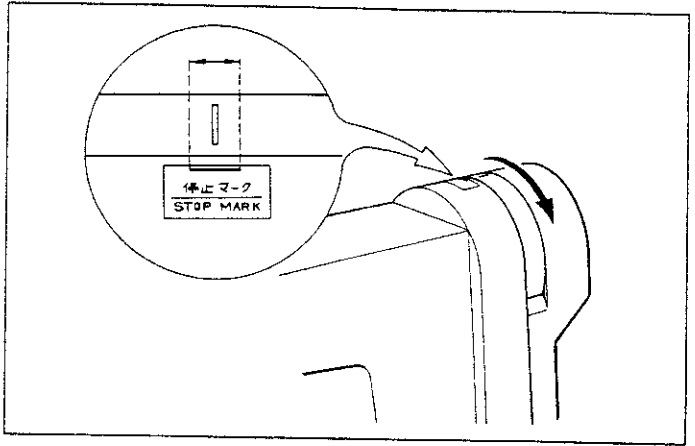
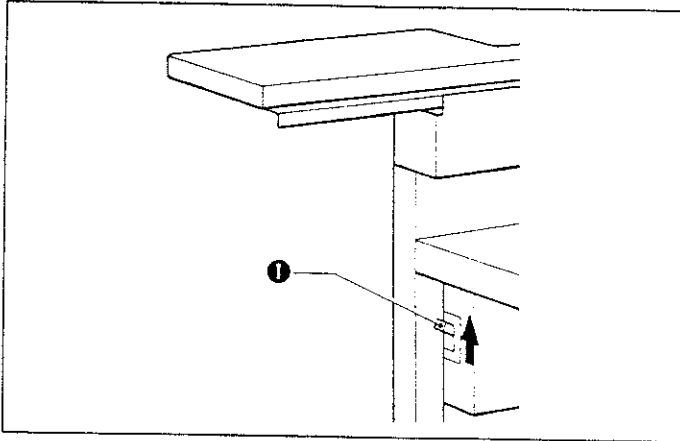

(1) Turn the power switch ❶ on.

* If DEFECTIVE NEEDLE DOWN POSITION is displayed, turn the pulley until the index on the pulley is within the range of the stop mark. Then press the start key.

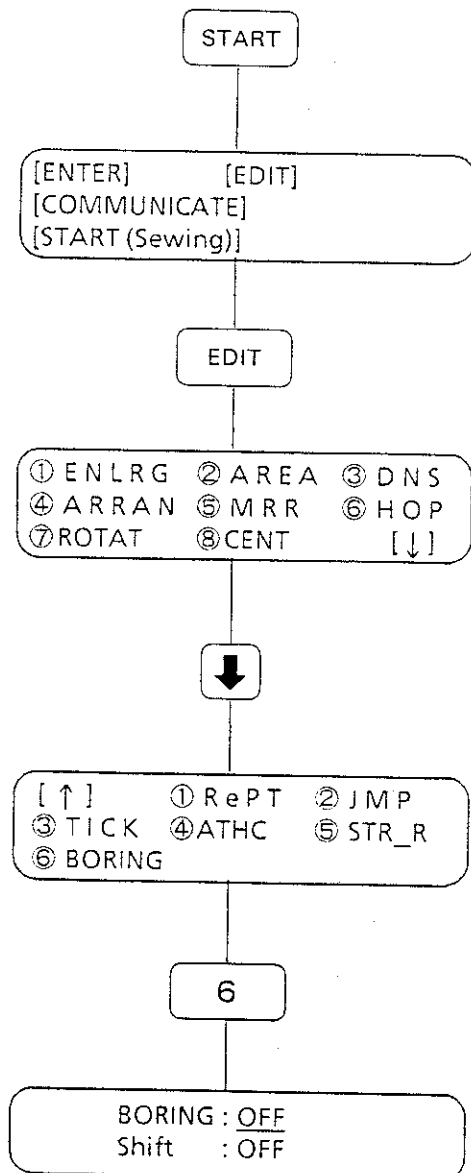

(2) The main menu will be displayed.

(3) Press the EDIT key to select the edit mode.

(4) Press the [↓] jog key to select the next menu.

(5) Press number key (6) to select boring.

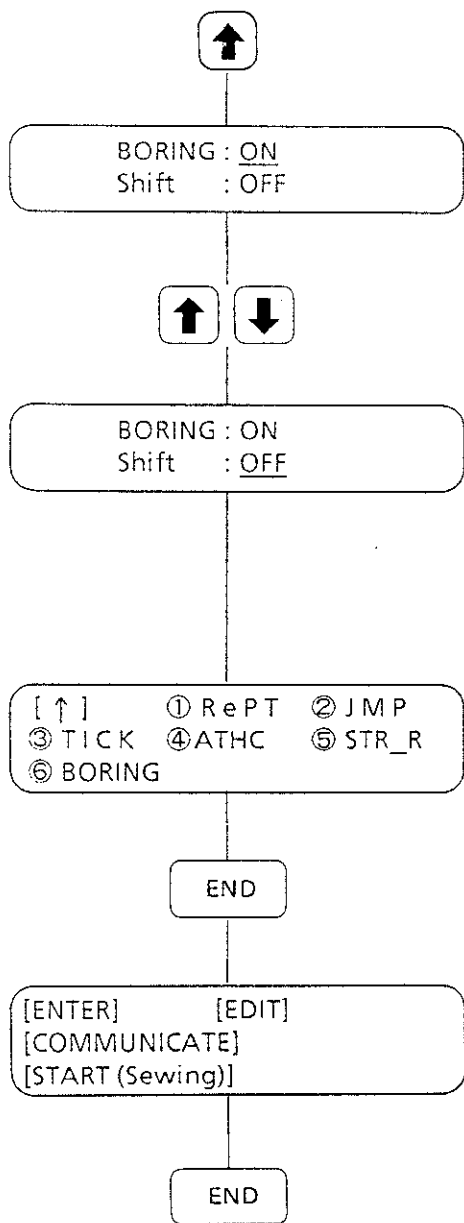

(6) Press the [↑] jog key to select BORING: ON.

(7) Press ENTER to move the cursor to SHIFT.
Use the jog keys [↑][↓] to select shift ON/OFF.

* If the boring position is not programmed with a shift, select Shift:ON.

* If the boring position is programmed with a shift, select Shift:OFF.

(8) Press END.

(9) Press END.

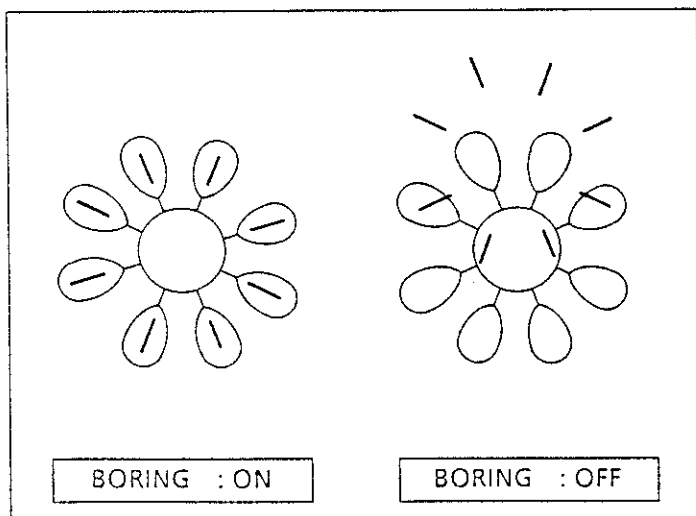

* Refer to the BAS-410 instruction manual for operations with the main menu.

PARTS LIST

1 Cap frame attachment

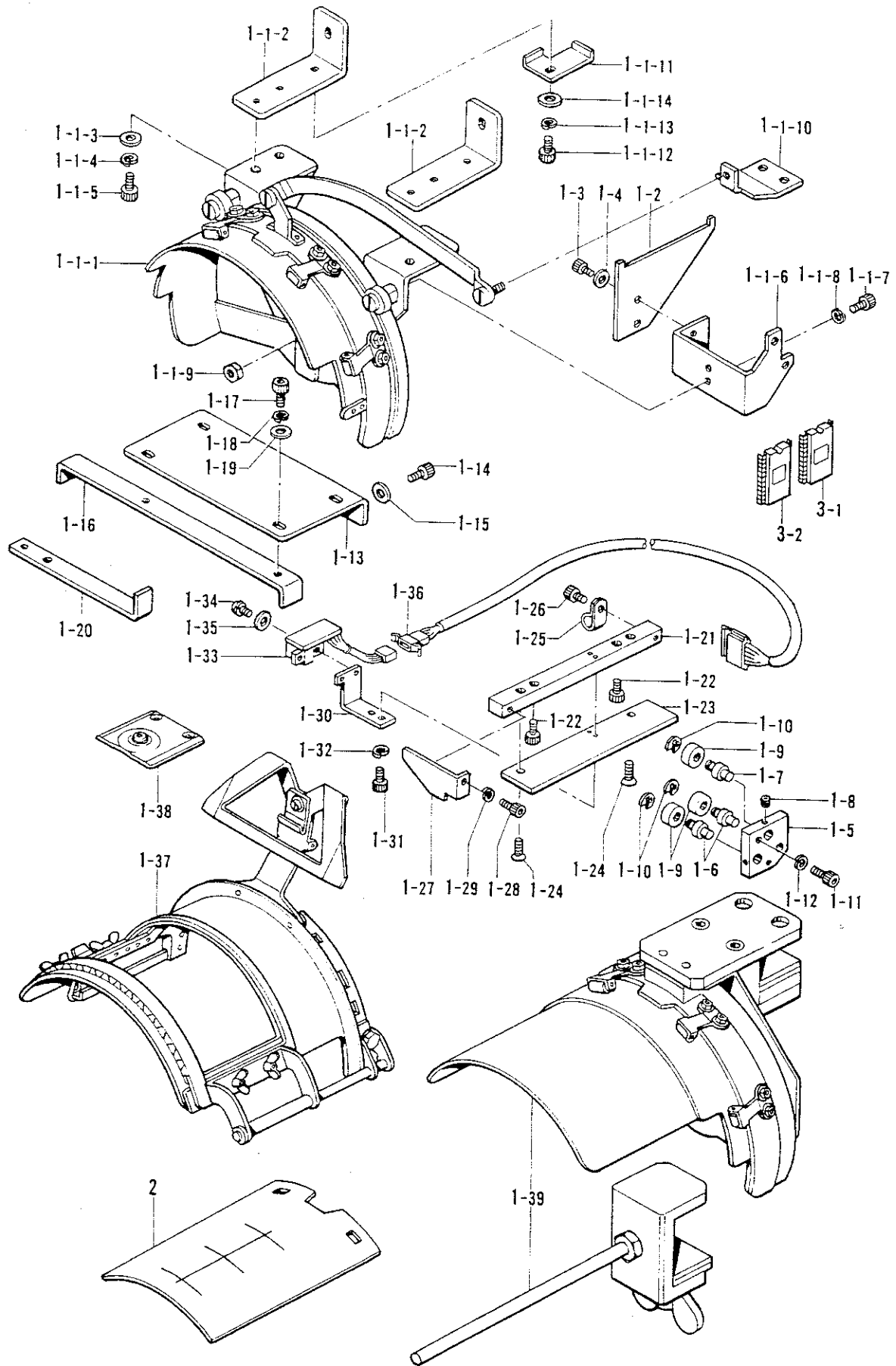

REF. NO.	NAME OF PARTS	Q'TY	CORD
1	CAP FRAME SET	1	S19962-001
1-1	CAP FRAME DEVICE ASSEMBLY	1	S19927-001
1-1-1	BASE FRAME ASSEMBLY	1	S19928-001
1-1-2	(L) BRACKET	2	S19929-001
1-1-3	BOLT 4 x 6	4	018400-622
1-1-4	SPRING WASHER 2-4	4	028040-242
1-1-5	PLAIN WASHER 4	4	025040-232
1-1-6	(U) BRACKET	1	S19930-001
1-1-7	BOLT 4 x 16	2	018401-622
1-1-8	SPRING WASHER 2-4	2	028040-242
1-1-9	NUT 4	2	021400-102
1-1-10	LEVER DRIVING PLATE	1	S19931-001
1-1-11	STOPPER (YR)	1	S19932-001
1-1-12	BOLT 4 x 6	1	018400-622
1-1-13	SPRING WASHER 2-4	1	028040-242
1-1-14	PLAIN WASHER 4	1	025040-232
1-2	(Y) LIMIT DOG	1	S19933-001
1-3	BOLT 4 x 6	2	018400-622
1-4	SPRING WASHER 2-4	2	028040-242
1-5	ROLLER SHAFT BASE	1	S19934-001
1-6	ROLLER SHAFT (E)	2	15768-001
1-7	ROLLER SHAFT (F)	1	157617-001
1-8	SET SCREW 4 x 5	3	014400-522
1-9	BALL BEARING (685ZZ)	3	070685-800
1-10	STOP RING E4	3	048040-242
1-11	BOLT 4 x 10	2	018401-022
1-12	SPRING WASHER 2-4	4	028040-242
1-13	BRACKET BASE	1	S19935-001
1-14	BOLT 4 x 6	2	018400-622

PARTS LIST

1 - Cap frame attachment

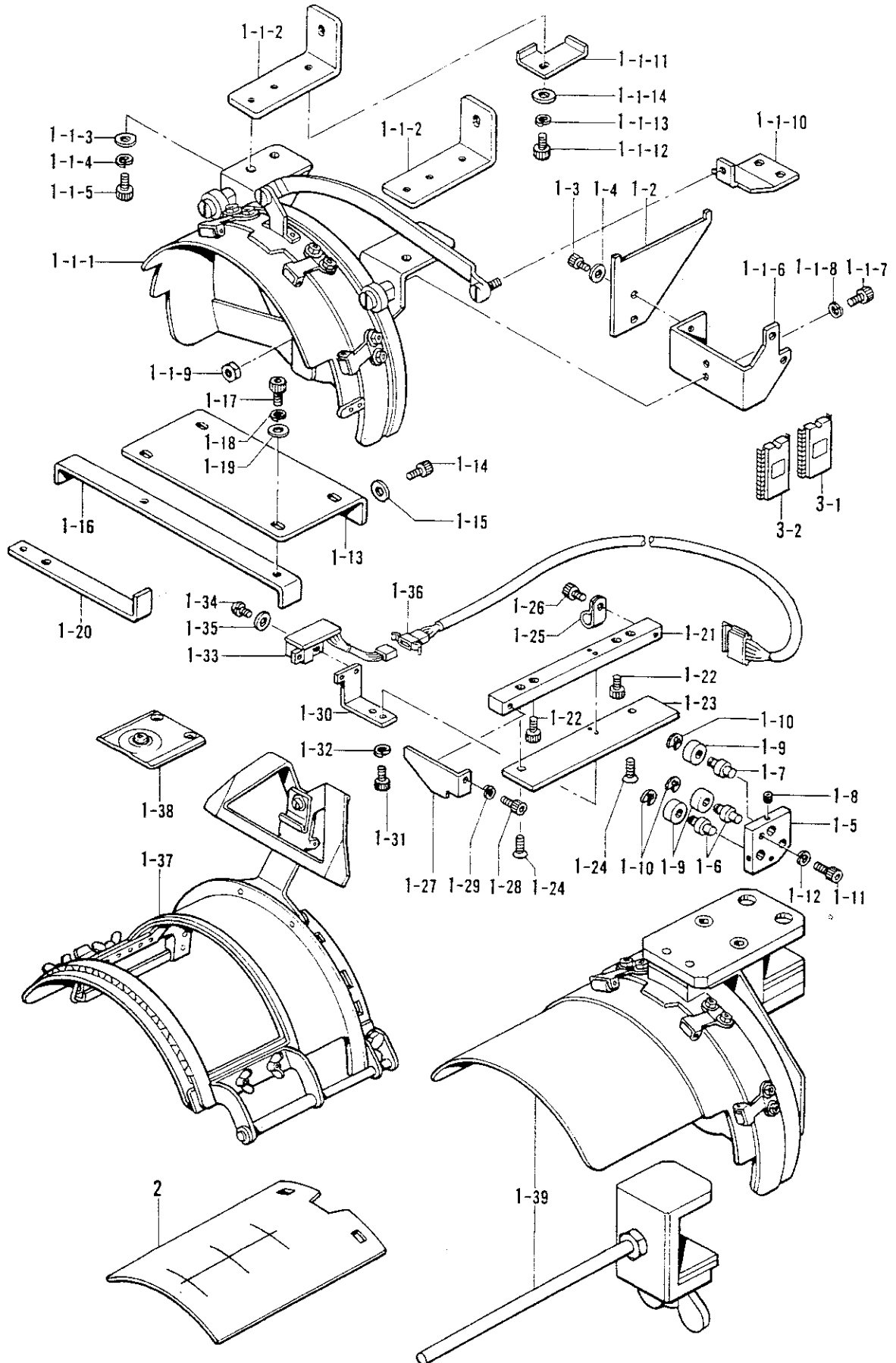

REF. NO.	NAME OF PARTS	Q'TY	CORD
1-15	PLATE WASHER 4	2	025040-232
1-16	(X) LIMIT	1	S19936-001
1-17	BOLT 4×8	4	018400-822
1-18	SPRING WASHER 2-4	4	028040-242
1-19	PLATE WASHER 4	4	025040-232
1-20	(X) STOPPER	1	S19937-001
1-21	RAIL BASE	1	S19938-001
1-22	BOLT 4.37 × 10	2	018681-022
1-23	RAIL PLATE	1	S19939-001
1-24	SCREW 4.37	2	148537-001
1-25	CLAMP NK-2N	1	S11816-000
1-26	BOLT 4×8	1	018400-822
1-27	STOPPER (YF)	1	S19940-001
1-28	BOLT 4×8	1	018400-822
1-39	SPRING WASHER 2-4	1	028040-242
1-30	SENSOR BRACKET	1	S19941-001
1-31	BOLT 3×6	2	018300-622
1-32	SPRING WASHER 2-3	2	028030-242
1-33	CAP SENSOR ASSEMBLY	1	S19942-001
1-34	SCREW 3×6D	2	215083-001
1-35	PLAIN WASHER 3	2	025030-135
1-36	CAP SENSOR HARNESS ASSEMBLY	1	S19943-001
1-37	CAP FRAME	1	S19944-001
1-38	NEEDLE PLATE FOR CAP FRAME	1	S19945-001
1-39	CAP FRAME DEVICE SET FRAME	1	S19946-001
2	HOME POSITION PLATE	1	S19947-001
3-1	PROM 410M KEY	1	S15428-001
3-2	PROM 410	1	S15364-000

PARTS LIST

2 Boring attachment

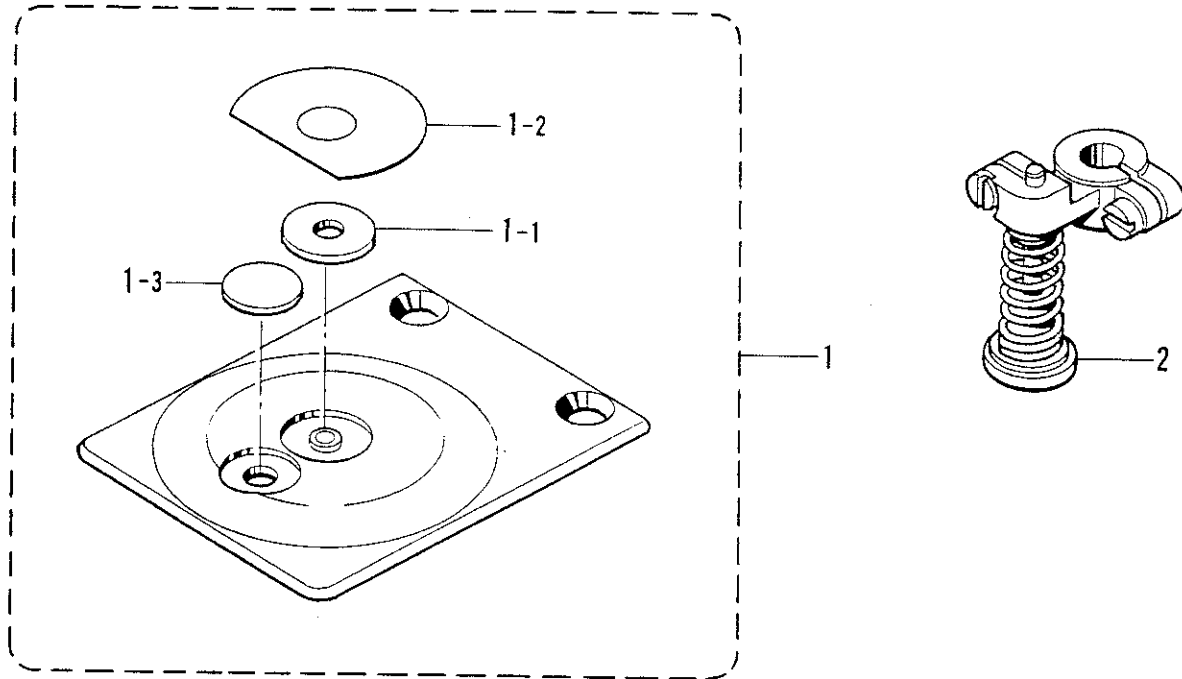

REF. NO.	NAME OF PARTS	Q'TY	CORD
1	NEEDLE PLATE FOR BORING	1	S19949-001
1-1	RUBBER	1	S17443-001
1-2	SEAL	1	S19958-001
1-3	NEEDLE PLATE KNIFE SUPPORT	1	S19957-001
2	BORING KNIFE SET	1	S19951-001

11/14

